

**CONTRACT AND SPECIFICATIONS
FOR
NDS BOILERFRONT PLATFORMS
CITY OF HASTINGS
HASTINGS, NEBRASKA
Contract No. HU 2025-68**

**Sealed Proposals Will Be Opened Promptly At
1:30 PM, Wednesday, May 14, 2025**

Bid Submitted By: _____



THIS BID DOCUMENT MUST BE SUBMITTED WITH BID

Table of Contents

**CONTRACT AND SPECIFICATIONS
FOR
NDS BOILERFRONT PLATFORMS
FOR
CITY OF HASTINGS
HASTINGS, NEBRASKA**

Contract No. HU 2025-68

I. BIDDING DOCUMENTS

Advertisement for Bids1
Instruction to Bidders.....2
Contact Sheet...3
Mailing Instructions4

II. CONTRACT FORMS

Proposal.....5-7
Formal Contract Agreement8-9
Performance Bond10-11
Affidavit.....12

III. TECHNICAL SPECIFICATIONS

Section 1 – General Conditions13-30
Section 2 – Special Conditions31-41
Section 3 – General Description and Scope of Work42-43
Drawings44

ADVERTISEMENT FOR BIDS

The City of Hastings, Nebraska, will receive bids for: **NDS Boilerfront Platforms HU 2025-68** until 1:30 p.m. at the City of Hastings, 1228 N Denver Ave., Hastings, Nebraska, on **Wednesday, May 14, 2025**, at which time and place all bids will be publicly opened and read aloud. **Brief description of project:** Provide materials and labor for the installation of two platforms for accessing equipment in the North Denver Station plant. If you plan on bidding and are not already on our approved bidders list for this project, you are REQUIRED to fill out the Plan Holders Submittal Form that is located on the City website: <https://www.cityofhastings.org/bids/>.

The Contract Documents, including plans and specifications, are on file at the City of Hastings Offices, 1228 N Denver Avenue, Hastings, Nebraska 68901. Copies of the plans and specifications in electronic (PDF) format may be obtained by visiting the City of Hastings Website: www.cityofhastings.org/bids. A paper copy is available for \$75.00, plus sales tax (\$5.25), plus shipping.

Each bid shall be accompanied by a certified check, drawn on a solvent bank in the State of Nebraska, or a bid bond in an amount of not less than five percent (5%) of the total bid of all contract construction costs, made payable to the City Treasurer of the City of Hastings, Nebraska, as security that the bidder to whom the contract may be awarded will enter into a contract to build all the improvements in accordance with this notice and give bond in the sum hereinafter provided for the construction of improvements.

No bid shall be withdrawn after opening of bids without the consent of the City of Hastings, Nebraska, for a period of sixty (60) days after scheduled time of closing bids.

Time is of the essence in this contract. In evaluating bid(s) received, the City will consider the timelines of completion of prior construction contracts, existing workload of bidders and available manpower that bidder commits to the project.

The successful bidder will be required to furnish a Performance and Payment Bond in the sum of the full amount of the Contract within ten (10) days of the date of award. No additional time will be allowed the Contractor for providing the Performance and Payment Bond.

DATED AT HASTINGS, NEBRASKA, this 15th day of April 2025.

Tyler Ficken, City Clerk

For City Clerk: Publish and Attach two (2) Proofs of Publication:

April 18, 2025
April 25, 2025

INSTRUCTIONS TO BIDDERS

All proposal information, including any unit price fill in sheets or other required information, shall be submitted on the proposal forms hereto attached. Copies of addenda, if any, shall be signed and attached. City of Hastings does NOT accept faxed or emailed bid returns.

Bidders shall inform themselves of all relevant matters, and, if awarded the contract, shall not be allowed any extra compensation by reason of any matter or thing concerning which such Bidder might not have fully informed themselves, prior to the bidding.

The Bidder bidding on the Specifications herein, who has exceptions to those called for in the Specifications, must so state in the space provided below and/or attach a letter explaining in detail the exceptions taken to those required in the Specifications. This letter of explanation shall become a part of the bid and shall be attached hereto. Failure by the Bidder to outline his exceptions will require the successful Bidder to comply with these Specifications.

EXCEPTIONS TO SPECIFICATIONS:

The Purchaser will not assume obligations resulting from losses or damages until acceptance of the equipment.

Checks of unsuccessful Bidders will be returned when their bids have been rejected and they will not be retained in excess of sixty (60) days from the date bids are opened. The check of the successful Bidder will be retained until the contract is awarded. Should the successful Bidder fail to perform as the Proposal and Specifications indicate, the City may use the check as liquidated damages within fifteen (15) days after written notice is given to the party who submitted the successful bid.

If any person contemplating submitting a bid for this contract is in doubt as to the true meaning of any part of the Specifications or other proposed contract documents, he may submit to Purchaser a written request for an interpretation thereof. The person submitting the request will be responsible for its prompt delivery. Any interpretation of the proposed documents will be made only by addendum duly issued or delivered to each person receiving a set of such documents. The Purchaser will not be responsible for any other explanation or interpretation of the proposed documents.

All addendums must be signed and attached to bid documents.

IF YOU HAVE QUESTIONS OR NEED HELP ON THESE SPECIFICATIONS

CONTRACT NO: HU 2025-68
NDS BOILERFRONT PLATFORMS

PLEASE CONTACT ANY OF THE FOLLOWING:

PROJECT QUESTIONS

Carson Moritz
Mechanical Engineer
Direct Line: 402-462-3678

Email: bidquestions@cityofhastings.org
cmoritz@cityofhastings.org

Derek Pfeifer
Production Engineer
Direct Line: 402-462-3673

Email: DPfeifer@cityofhastings.org

GENERAL QUESTIONS OR REQUESTS

Rena Griess
Administrative Assistant – Engineering Dept, City of Hastings
Ph# 402-462-3665
Fax# 402-462-3666
Email: bidquestions@cityofhastings.org



IMPORTANT MAILING (OR HAND DELIVERY) INSTRUCTIONS

Please address your return envelope as shown in the example below. All bids must be sealed in a properly marked envelope.

To hand deliver please drop off between the hours of 8am – noon and 1pm – 5pm Monday-Friday.

Your Return Address

City of Hastings
Attn: Renae Griess
1228 N Denver Avenue
Hastings, NE 68901

**This Information MUST BE typed or written in the lower left hand corner of return envelope
OR SIMPLY CUT OUT AND TAPE ON YOUR RETURN ENVELOPE**

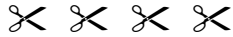

BID DOCUMENTS ENCLOSED

ATTN: Renae Griess, Administrative Assistant
Contract No: HU 2025-68
NDS Boilerfront Platforms
Bid Opens: Wednesday, May 14, 2025 @ 1:30 pm

If returning Fed-X or similar carrier, please enclose the bid in an “inner” envelope which is sealed. Please make sure BOTH envelopes are properly marked on the OUTSIDE OF THE ENVELOPE as shown in the example above.

One bid per envelope. Bid submittal via email is not allowed. Bids must be checked in to the City of Hastings prior to 1:30 pm deadline.

**PROPOSAL FOR
NDS BOILERFRONT PLATFORMS**

Contract No. HU 2025-68

TO: City of Hastings
1228 N. Denver Ave
Hastings, NE 68901

Bid Opening: May 14, 2025 (Wednesday)
SEALED BIDS MUST BE RECEIVED BY 1:30
P.M. AND WILL BE OPENED PROMPTLY AT
THAT TIME

We, the undersigned, being familiar with all parts of these documents, being Notice to Bidders, Bid Proposal Price Sheets, Contract Document Forms, Plans and Specifications, Affidavit, and all other parts of this document, do herein submit our proposal to **replace the NDS Boilerfront Platforms**, for the following price, **including 7% Nebraska Sales Tax**. The labor portion is not subject to sales tax; however, the material portion is taxed accordingly. See following tax rules and regulation language.

Item #	Qty	Description	Unit Price	Total
1	LS	Replace Unit 4 Boilerfront Platform		
2	LS	Replace Unit 5 Boilerfront Platform		
TOTAL				
				\$
In Words				

For purposes of sales/use tax, this project falls under Nebraska Sales and Use Tax Regulation 1-017 for Contractors. By definition, a contractor is “any person who repairs property annexed to, or who annexes property to, real estate, including leased property, by attaching building materials to the annexed property or improvement being built or repaired, or who arranges for annexation of property.” Please refer to www.revenue.nebraska.gov/salestax.html for additional information.

For calculating this proposal:

- All contractors are to include sales/use tax on materials in the bidder’s prices, if applicable.
- **Option 1 contractors must separately state materials, sales tax, labor, and other charges on all invoices for the project. Any invoices submitted that do not include this required breakdown of the charges will not be accepted for payment. (This requirement does not apply to Option 2 or 3 contractors.)**
- The sales/use tax rate on building materials is 7.0% for projects within Hastings’ city limits and 5.5% for projects outside of city limits.
- Contractor labor charges for this proposal are not subject to sales/use tax per the Nebraska Department of Revenue Notice to Contractors effective October 1, 2007.
- In submitting this bid, the bidder certifies that he will comply with all applicable laws, ordinances, and codes of the City of Hastings and the State of Nebraska.
- For this project, Contractor will supply all materials.

**PROPOSAL FOR
NDS BOILERFRONT PLATFORMS
Contract No. HU 2025-68**

What contractor option have you registered with the Nebraska Department of Labor (must select one)? Please refer to <https://dol.nebraska.gov> for additional information.

Option 1 _____

Option 2 _____

Option 3 _____

Is Nebraska Sales/Use Tax included in the above prices.

Yes _____ No _____

(ALL COSTS TO INCLUDE CITY AND STATE SALES TAX)

As noted in the proposal sheet one contract will be awarded for the sum total of all Bid Sections.

Activity	Proposed Date
Contract award date	May 28, 2025
Completed Unit 4 Boilerfront Platform	
Completed Unit 5 Boilerfront Platform	

Exceptions: No Yes (If yes, list on ***“Instructions to Bidders”*** page)

Any modification of bid proposal will be considered non-conformance of the bid. All exceptions to the proposal shall be noted as an exception to the bid.

City of Hastings may at its own discretion delete any project area and / or component prior to award of contract.

In submitting this proposal, it is further understood that the City of Hastings reserves the right to reject any or all proposals and may waive any informalities and may accept the proposal which best suits its needs. It is further understood that this proposal may not be withdrawn for a period of sixty days (60) days after bids are opened.

All proposals shall have original signatures. Electronic time-stamped signatures will be acceptable. Photocopied or printed versions of bid bonds will be accepted without original signatures, however a hardcopy with original signatures must be received by City of Hastings within 5 business days.

**PROPOSAL FOR
NDS BOILERFRONT PLATFORMS
Contract No. HU 2025-68**

OFFICIAL NAME & ADDRESS

Firm Name	Signature
Address	Typed or Printed Name
City, State, Zip	Title
Phone No.	Date
Fax No.	Email Address

**ALL BIDS MUST BE CHECKED IN TO THE CITY OF HASTINGS
PRIOR TO 1:30 PM DEADLINE**

AGREEMENT

THIS AGREEMENT, made and entered into this day of 2025, by and between the City of Hastings, Party of the First Part, hereinafter called the "Purchaser" or "City", and a of (town) in the State of , Party of the Second Part, hereinafter called the "Contractor".

WITNESSETH: THAT,

WHEREAS: The Purchaser has caused the necessary contract documents to be prepared for defining material, equipment, and/or labor to be supplied to the City of Hastings and delivered complete as specified in the accompanying contract documents.

WHEREAS: The Purchaser has advertised for bids from Contractors, has received said bids, analyzed same and duly awarded a contract to the "Contractor", "Party of the Second Part", for material, equipment, and/or labor as hereinafter set forth and as stated more in detail in the Proposal and related contract documents to wit; Notice to Bidders, Instructions to Bidders, Specifications; all of which documents are attached hereto and made a part of this Contract.

NOW, THEREFORE: It is hereby agreed that for the sum of . (\$)

to be paid by the Purchaser, within Thirty (30) days after the acceptance of material, equipment, and/or labor by the Purchaser, to the Contractor, the Contractor agrees to furnish all materials, equipment, and/or labor as required by the accompanying specifications, and the aforesaid contract documents, for **NDS Boilerfront Platforms, HU 2025-68.**

All materials, equipment, and/or labor shall be in accordance with the accompanying contract documents and specifications which are as much a part of this Agreement as if repeated verbatim herein.

It is further agreed that the Contractor will start work promptly, furnish the necessary drawings promptly and complete the work in the number of days set forth in the Proposal.

AGREEMENT

IN WITNESS WHEREOF: The Parties of the First and Second Parts have hereto set their hands and seals on the day and year above written.

CITY OF HASTINGS
Party of the First Part

By: _____

Date: _____

ATTEST:

City Clerk

CONTRACTOR
Party of the Second Part

SEAL

By: _____

Title: _____

Date: _____

APPROVED TO FORM:

City Attorney

Note: If executed by one other than President, Partner or the individual Owner, a Power-of-Attorney authorizing execution should accompany this Contract.

PERFORMANCE BOND

KNOW ALL MEN BY THESE PRESENTS:

That we, the undersigned, _____,
as principal, and _____,
a corporation organized and existing under the laws of the State of _____,
and duly authorized to transact business in the State of Nebraska, as surety are held and firmly
bound unto the CITY OF HASTINGS, NEBRASKA, a municipal corporation organized and
existing under the laws of the State of Nebraska, hereinafter referred to as CITY, in the penal sum
of _____ Dollars (\$ _____),
lawful money of the United States, for the payment of which will and truly be made, we the said
principal and the said surety do hereby bind ourselves, our heirs, executors, administrators and
assigns, jointly and severally, by these presents as follows:

The condition of this obligation is such that, whereas the principal, by an instrument in writing
attached hereto and bearing the date of _____, 20____, has agreed with the
CITY to do all work necessary and to furnish all labor, materials, supplies, tools and equipment to

as specified thereby and in the specifications, proposals and contract forming the Contract
Documents attached thereto and made a part hereof:

NOW THEREFORE, if the principal shall well and truly in good, sufficient and in a
workmanlike manner, and to the satisfaction of the CITY perform and complete the work required,
and shall defend, indemnify and save harmless the CITY against all damages, claims, demands,
expenses and charges of every kind (including claims of patent infringement) arising from any act,
omission or neglect of said principal, his agents, servants or employees, with relation to said work,
and shall pay all costs, charges, rentals and expenses for labor, materials, supplies and equipment
and deliver the said improvement to the CITY completed and ready for operation and free from all
encumbrances or claims for labor, materials or otherwise, and shall pay all other expenses lawfully
chargeable to the CITY, and this bond shall also be for the use and benefit of all persons who may
perform any work or labor or furnish any material in the execution of said Contract and may be

sued on thereby in the name of any such party claiming the benefit hereof, then this obligation shall be void, otherwise the same shall remain in full force and effect. This obligation shall be in full force and effect for the full guarantee period provided in the specifications contained herein.

PROVIDED FURTHER, that said surety for value received hereby stipulates and agrees that no change, extension of time, alteration or addition to the terms of the Contract or the work to be performed thereunder or the specifications accompanying the same shall in any way affect its obligation on this bond, and it does hereby waive notice of any change, extension of time, alteration or addition to terms of the Contract, to the work or to the specifications.

PROVIDED FURTHER, that if the principal of his, their or its subcontractor or subcontractors fail to duly pay for any labor, materials team, hire sustenance, provisions, provender or any other supplies or materials used or consumed by such contractor of his, their or its subcontractors in performance of the work contracted to be done, the surety will pay the same in any amount not exceeding the sum specified in the bond together with interest as provided by law.

IT WITNESS WHEREOF, said principal and surety have hereunto set their hands and seals at _____ this ____ day of _____, 20____,

This Bond is executed in triplicate counterparts.

	_____	Principal
(SEAL)	_____	Street Address
_____	_____	City, State, Zip
Witness	_____	Name of Person Executing
	_____	Surety
ATTEST:	_____	By: _____
_____	_____	Title: _____

SECTION 1 - GENERAL CONDITIONS

GENERAL CONDITIONS

GC.1 Contract Documents

It is understood and agreed that the Notice to Bidders, Instructions to Bidders, Proposal, Proposal Data, Contract Agreement, Performance Bond, Payment Bond, General Conditions, Special Conditions, Specifications, Drawings, Addenda, and Change Orders issued by the Purchaser or the Engineer, and specifications and engineering data furnished by the Contractor and accepted by the Purchaser, are each included in this Contract and the work shall be done in accordance therewith.

GC.2 Definitions

Words, phrases, or other expressions used in these contract documents shall have meanings as follows.

1. "Contract" or "contract documents" shall include the items enumerated above under CONTRACT DOCUMENTS.
2. "Purchaser" shall mean the City of Hastings named and designated in the Contract Agreement as "Party of the First Part," and their duly authorized agents. All notices, letters, and other communication directed to the Purchaser shall be addressed and delivered to:

City of Hastings – Engineering Department
Attention: Carson Moritz, Mechanical Engineer
1228 N Denver Ave
Hastings, Nebraska 68901

Or, by email to cmoritz@cityofhastings.org
3. "Contractor" shall mean the corporation, company, partnership, firm or individual named and designated in the Contract Agreement as the "Party of the Second Part," who has entered into this Contract for the performance of the work covered thereby, and its, his, or their duly authorized representatives.
4. "Subcontractor" shall mean and refer only to a corporation, partnership, or individual having a direct contract with the Contractor for performing work covered by these contract documents.
5. "Engineer" shall also refer to City of Hastings as the purchaser.
6. "Date of contract," or equivalent words, shall mean the date written in the first paragraph of the Contract Agreement.
7. "Day" or "days," unless herein otherwise expressly defined, shall mean a calendar day or days of 24 hours each.
8. "The work" shall mean the equipment, supplies, materials, labor, and services to be furnished under the contract and the carrying out of all obligations imposed by the contract documents.
9. "Drawings" or "plans" shall mean all (a) drawings furnished by the Purchaser as a basis for proposals, (b) supplementary drawings furnished

SECTION 1 - GENERAL CONDITIONS

by the Purchaser to clarify and to define in greater detail the intent of the contract drawings and specifications, (c) drawings submitted by the successful bidder with his proposal, provided such drawings are acceptable to the Purchaser, (d) drawings furnished by the Purchaser to the Contractor during the progress of the work, and (e) engineering data and drawings submitted by the Contractor during the progress of the work, provided such drawings are acceptable to the Engineer.

10. Whenever in these contract documents the words "as ordered," "as directed," "as required," "as permitted," "as allowed," or words or phrases of like import are used, it shall be understood that the order, direction, requirement, permission, or allowance of the Purchaser or Engineer is intended only to the extent of judging compliance with the terms of the contract; none of these terms shall imply that the Purchaser or the Engineer has any authority or responsibility for supervision of the Contractor's forces or construction operations, such supervision and the sole responsibility therefor being strictly reserved for the Contractor.
11. Similarly, the words "approved," "reasonable," "suitable," "acceptable," "proper," "satisfactory," or words of like effect and import, unless otherwise particularly specified herein, shall mean approved, reasonable, suitable, acceptable, proper, or satisfactory in the judgment of the Purchaser or Engineer, to the extent provided in (10) above.
12. Whenever in these contract documents the expression "it is understood and agreed" or an expression of like import is used, such expression means the mutual understanding and agreement of the parties executing the Contract Agreement.
13. "Official acceptance" shall mean the Purchaser's written acceptance of all work performed under this Contract, based on the Engineer's final inspection and issuance of a final payment certificate.
14. "Project completion" shall mean that the Air Heater is ready for operation and all old material has been disposed of per the specification.
15. "Final Acceptance" shall mean that all work has been completed in accordance with these specifications, the project has been walked down, punch list items have been completed, and Purchaser is ready to accept the Work as complete.
16. "Stop Work Order" shall mean that the Purchaser will provide a written order to the Contractor requiring the Contractor to stop all, or any part of, the work called for by this Contract, for a time defined by the order. The order shall specify the reasoning for the suspended work, which may include, but are not limited to, engineering considerations, changes to the project scope, safety or environmental concerns, or other issues detrimental to the project. Upon receipt of the order, the Contractor shall immediately comply with its terms and take all reasonable steps to minimize the incurrence of costs allocable to the work covered by the order. As soon as practical, the Purchaser and Contractor shall discuss the

SECTION 1 - GENERAL CONDITIONS

impacted activities, schedule, materials, labor, and equipment. If applicable, Purchaser and Contractor will seek to negotiate an equitable adjustment in the schedule, Contract price, or both, and the contract shall be modified, or a change order issued, as necessary. Upon any agreement and finalization of commercial conditions, Purchaser to provide written order to cancel the stop work order.

GC.3 Execution of the Contract

Once the bids have been evaluated, the Purchaser will electronically submit the Contract Agreement to the Contractor. The Contractor shall sign the Contract Agreement and return to Purchaser for the final approval process. Upon final approvals, the Contract Agreement will be signed by the Purchaser and electronically returned to the Contractor. Contractor shall then mail one hardcopy of required bonds, one electronic or hardcopy of insurance documents, and one electronic or hardcopy of power of attorney forms to the Purchaser. The date of contract on the bond forms and power of attorney forms shall match the date provided on the Contract Agreement by the Purchaser.

The Purchaser will review the final documents and electronically send a final conformed contract to the Contractor.

GC.4 Legal Addresses

The business address of the Contractor listed in the Proposal is hereby designated as the place to which all notices, letters, and other communication to the Contractor will be mailed or delivered. The address of the Purchaser appearing in section GC.2 is hereby designated as the place to which all notices, letters, and other communication to the Purchaser shall be mailed or delivered. Either party may change his address at any time by an instrument in writing delivered to the Engineer and to the other party.

GC.5 Scope and Intent of Contract Documents

The various parts of the contract documents are intended to supplement but not necessarily duplicate each other. Any work exhibited in one part and not in another shall be executed as if it had been set forth in all parts, so that the work will be performed according to the complete design as determined by the Engineer.

Should anything necessary for a clear understanding of the work be omitted from the contract documents, or should the requirements appear to be in conflict, the Contractor shall secure written instructions from the Engineer before proceeding with the work affected thereby. It is understood and agreed that the work shall be performed according to the true intent of the contract documents.

GC.6 Independent Contractor

The relationship of the Contractor to the Purchaser shall be that of an independent contractor.

GC.7 Assignment

The Contractor shall not assign the work, or any part thereof, without the previous written consent of the Purchaser, nor shall he assign, by power of attorney or otherwise, any of the money payable under this Contract unless written consent of the Purchaser has been obtained. No right under this Contract, nor claim for any money due or to become due

SECTION 1 - GENERAL CONDITIONS

hereunder shall be asserted against the Purchaser, or persons acting for the Purchaser, by reason of any so-called assignment of this Contract or any part thereof, unless such assignment has been authorized by the written consent of the Purchaser. In case the Contractor is permitted to assign moneys due or to become due under this Contract, the instrument of assignment shall contain a clause subordinating the claim of the assignee to all prior liens for services rendered or materials supplied for the performance of the work.

GC.8 Oral Statements

It is understood and agreed that the written terms and provisions of this agreement shall supersede all oral statements of representatives of the Purchaser, and oral statements shall not be effective or be construed as being a part of this Contract.

GC.9 Reference Standards

Reference to the standards of any technical society, organization, or association, or to codes of local or state authorities, shall mean the latest standard, code, specification, or tentative standard adopted and published at the date of taking bids, unless specifically stated otherwise.

GC.10 Source of Materials

To the extent possible, materials, and equipment (including components thereof) furnished under these specifications shall be produced, processed, manufactured, and assembled within the United States of America. Substitution of foreign materials for domestic materials will not be permitted unless such substitution is clearly stated in the Proposal and accepted by the Purchaser.

GC.11 Contractor to Check Drawings and Lists

The Contractor shall check all dimensions, elevations, and quantities indicated on the drawings and lists furnished to him by the Engineer. The Contractor shall notify the Engineer of any discrepancy between the drawings and the conditions at the site, or any error or omission in the drawings, or in the layout as given by stakes, points, or instructions, which he may discover in the course of the work. The Contractor will not be allowed to take advantage of any error or omission in the drawings or other contract documents that a reasonable inspection of them by Contractor would reveal. Full instructions will be furnished by the Engineer should such error or omission be discovered, and the Contractor shall carry out such instructions as if originally specified.

GC.12 Figured Dimensions to Govern

Dimensions and elevations indicated on the drawings shall be accurately followed even though different from scaled measurements. No work indicated on the drawings, the dimensions of which are not indicated, shall be executed until necessary dimensions have been obtained from the Engineer.

GC.13 No Waiver of Rights

Neither the inspection by the Purchaser or Engineer or any of their officials, employees, or agents, nor any order by the Purchaser or Engineer for payment of money, or any payment for, or acceptance of, the whole or any part of the work by the Purchaser or Engineer, nor any extension of time, nor any possession taken by the Purchaser or its employees, shall operate

SECTION 1 - GENERAL CONDITIONS

as a waiver of any provision of this Contract, or of any power herein reserved to the Purchaser, or any right to damages herein provided, nor shall any waiver of any breach in this Contract be held to be a waiver of any other or subsequent breach.

GC.14 Authority of the Engineer

To prevent delays and disputes, and to discourage litigation, it is agreed by the parties to this Contract that the Engineer shall determine the quantities of work which are to be paid for under the contract and shall resolve all questions in relation to the work.

If, in the opinion of the Contractor or the Purchaser, a decision made by the Engineer is not in accordance with the meaning and intent of the contract, either party may file with the Engineer and the other party to the contract, within 30 days after receipt of the decision, a written objection to the decision. Failure to file an objection within the allotted time will be considered acceptance of the Engineer's decision and the decision shall become final and conclusive.

The Engineer's decision and the filing of the written objection thereto shall be a condition precedent to the right to request arbitration or to start action in court.

It is the intent of this agreement that there shall be no delay in the execution of the work and the decision of the Engineer as rendered shall be promptly observed.

GC.15 Engineering Inspection

The Purchaser may appoint (either directly or through the Engineer) such inspectors as the Purchaser deems proper to inspect the work for compliance with the contract documents. The Contractor shall furnish all reasonable assistance required by the Engineer, or inspectors, for the proper inspection of the work. Should the Contractor object to any interpretation of the contract by an inspector, the Contractor may make written appeal to the Engineer for a decision.

Inspectors shall have the authority to reject work which is unsatisfactory, faulty, or defective or does not conform to the requirements of the contract documents. Inspection shall not relieve the Contractor from any obligation to construct the work strictly in accordance with the contract documents.

Upon the failure of the Contractor or its Subcontractors to comply with any of the requirements of this Contract (but not limited to quality or safety), the Purchaser shall have the authority to stop any portion of the work affected by such failure until such failure is remedied. If the Purchaser issues a Stop Work Order, the Purchaser shall not be liable for any costs or expenses claimed by Contractor arising out of such issuance. The construction schedule shall not be delayed or extended as a result of the Purchaser's issuance of a Stop Work Order.

GC.16 Contractor Default

If the work to be done under this Contract is abandoned by the Contractor; or if this Contract is assigned by him without the written consent of the Purchaser; or if the Contractor is adjudged bankrupt; or if a general assignment of his assets is made for the benefit of his

SECTION 1 - GENERAL CONDITIONS

creditors; or if a receiver is appointed for the Contractor or any of his property; or if at any time the Engineer certifies in writing to the Purchaser that the performance of the work under this Contract is being unnecessarily delayed, that the Contractor is violating any of the conditions of this Contract, or that he is executing the same in bad faith or otherwise not in accordance with the terms of said contract; or if the work is not substantially completed within the time named for its completion or within the time to which such completion date may be extended; then the Purchaser may serve written notice upon the Contractor and his surety of the Purchaser's intention to terminate this Contract. Unless within 5 days after the serving of such notice, a satisfactory arrangement is made for continuance, this Contract shall terminate. In the event of such termination, the surety shall have the right to take over and complete the work, provided that if the surety does not commence performance within 30 days, the Purchaser may take over and prosecute the work to completion, by contract or otherwise. The Contractor and his surety shall be liable to the Purchaser for all excess cost sustained by the Purchaser by reason of such prosecution and completion. The Purchaser may take possession of, and utilize in completing the work, all materials, equipment, tools, and plant on the site of the work.

GC.17 Beginning, Progress, and Completion of the Work

The time of completion is a basic consideration of this Contract. Unless otherwise specified in these contract documents or advised by written order of the Purchaser, the Contractor shall begin work within 10 days after the date of contract. The work shall be prosecuted to completion in accordance with the specified schedule, subject to adjustment as provided in these contract documents.

A detailed construction schedule shall be prepared by the Contractor and submitted to the Purchaser for review. The schedule shall contain the various activities required to perform the work and the dates the activities will be started and completed in order to complete the work in accordance with the specified schedule requirements. The Contractor is responsible for determining the sequence and time estimates of the detailed construction activities. However, the Purchaser reserves the right to require the Contractor to modify any portion of the schedule the Purchaser determines to be impracticable or unreasonable; as required to coordinate the Contractor's activities with those of other contractors, if any, engaged in work for the Purchaser on the site; to avoid undue interference with the Purchaser's operations; and to assure completion of the work by the date or dates stipulated. Upon acceptance by the Purchaser of the Contractor's detailed construction schedule, the Contractor will be responsible for maintaining such schedule.

If at any time the Contractor's work is behind schedule, he shall immediately put into effect definite procedures for getting the work back on schedule. The procedures shall be subject to review and modification by the Purchaser.

GC.18 Hindrances and Delays

The Contractor expressly agrees that in undertaking to complete the work within the time specified, he has made allowances for all hindrances and delays which might usually be expected to occur in performing the work. No claims shall be made by the Contractor for such hindrances and delays.

SECTION 1 - GENERAL CONDITIONS

If the Contractor experiences hindrances and delays which, in his opinion, are not usually to be expected in the performance of the work and which affect the performance of the work, he may request a change in the contract. Such hindrances and delays may include, but not be limited to, acts or failure to act by the Purchaser or other contractors employed by the Purchaser, fires, floods, labor disputes, epidemics, or acts of God. Such hindrances and delays shall not include rain, snow, or other non-severe inclement weather. Claims by the Contractor for any change in the contract due to such hindrances and delays shall be made in accordance with the requirements of Article GC.22, CHANGES TO THE CONTRACT. The Contractor shall use all reasonable means to minimize the extent of the delay.

GC.19 Suspension of Work

The Purchaser reserves the right to suspend and reinstate execution of the whole or any part of the work without invalidating the provisions of the contract. Suspension or reinstatement of the work will be by written notice to the Contractor from the Purchaser.

Suspension of work shall not automatically entitle the Contractor to additional compensation or a change in the contract time; however, the Contractor will be reimbursed for real and unavoidable direct costs incurred by him as a result of such suspension and/or the contract will be extended as required to compensate for any delay due to such suspension. Claims by the Contractor for change of contract time or an adjustment of the contract price, due to work suspensions ordered by the Purchaser shall be made in accordance with the requirements of Article GC.22, CHANGES TO THE CONTRACT. The Contractor shall use all reasonable means to minimize the consequences of such suspension.

GC.20 Cancellation of Work

The Purchaser reserves the right to cancel the unshipped portion of the work by giving written notice to the Contractor. In the event of cancellation, the Purchaser will pay the Contractor reasonable and proper cancellation costs.

Cancellation of the work shall not constitute the basis for a claim for damages or loss of anticipated profits.

The Contractor shall, after consultation with the Purchaser, take all reasonable steps to minimize the costs related to cancellation. The Contractor shall provide the Purchaser with an accounting of costs claimed, including adequate supporting information, and the Purchaser may, at its expense, audit the claimed costs and supporting information.

GC.21 Modifications

The Contractor shall modify the work whenever so ordered by the Purchaser and such modifications shall not affect the validity of the contract. Modifications may involve changes in the amount of the work to be performed or changes in the contract time for which appropriate changes to the contract will be made.

Contract changes due to modifications shall be made in accordance with the requirements of Article GC.22, CHANGES TO THE CONTRACT.

SECTION 1 - GENERAL CONDITIONS

GC.22 Changes to the Contract

The contract may be changed only by duly executed change orders issued by the Purchaser.

If, in the opinion of the Purchaser or the Contractor, any event or action by the other party justifies a change in the contract, either party shall initiate with the other party, within 5 days after such event or action, a request for a change to the contract. All documentation required to substantiate the proposed change shall be submitted within a minimum reasonable time after initiating the request for change. Upon the parties reaching agreement regarding the proposed change, the Purchaser will issue a written change order therefor.

Notwithstanding the foregoing provisions requiring duly authorized change orders, in the event agreement has been reached between authorized representatives of the parties regarding the change in the contract pending processing of such change order, the Contractor shall proceed with the work on the basis of written interim authorization from the Purchaser.

If the Contractor claims that any instruction, request, drawing, specifications, or other directive or action of the Purchaser or the Engineer constitutes a change in the contract, but has not been authorized as such by a change order in writing by the Purchaser, the Contractor shall immediately request a written interim authorization and proceed without delay to perform the work in accordance with such authorization. The Contractor shall provide written notice of the claim or dispute to the Engineer and the Purchaser within 5 days of the request for interim authorization. The Contractor's failure to give said written notice within the 5 day period shall constitute a waiver and relinquishment of any such claim or dispute. The Purchaser's written interim authorization shall not constitute approval of the claim for increased or decreased work, but shall be a condition precedent to the Contractor's right to receive payment for such work and to the Contractor's right to prosecute or maintain any proceeding to recover for such work.

GC.22.1 Contract Price Changes

The contract price may be changed due to modifications which involve extra work or decreased work; or due to work suspensions, hindrances, and delays over which the Contractor has no control. Claims for changes in the contract price shall conform to the requirements specified herein.

GC.22.1.1 Increased Price

If a change in the contract is required due to work suspensions or hindrances and delays, the contract price will be increased according to agreed lump sums, agreed acceleration costs, or other demonstrable costs submitted by the Contractor and substantiated to the satisfaction of the Purchaser.

If a change in the contract price is required due to a modification which increases the amount of the work, and the added work or any part thereof is of a type and character which can properly and fairly be classified under one or more unit price items of the contract, then the contract price will be increased according to the amount actually done and at the applicable unit price. Otherwise, such work shall be paid for as herein-after provided.

Contract price changes for modifications involving extra work will be based on agreed lump sums or on agreed unit prices whenever the Purchaser and the Contractor agree upon such

SECTION 1 - GENERAL CONDITIONS

prices before the extra work is started; otherwise, payments for extra work will be based on actual direct cost plus the specified percentage allowance.

For the purpose of determining whether proposed extra work will be authorized, or for determining the payment method for extra work, the Contractor shall submit to the Engineer, upon request, a detailed cost estimate for proposed extra work. The estimate shall indicate itemized quantities and charges for all elements of direct cost. Charges for the Contractor's and subcontractor's extra profit, extra general superintendence, extra field office expense, and extra overheads shall be indicated as a percentage addition to the total estimated direct cost. Unless otherwise agreed upon by the Contractor and the Purchaser, such percentage additions shall be 15 percent for the extra work performed by the Contractor's own forces or 20 percent for extra work performed by a subcontractor.

When payment for extra work is based on actual direct cost, the Contractor will be paid the actual direct cost plus an allowance of 15 percent if the extra work is performed by the Contractor's own forces or 20 percent if the extra work is performed by a subcontractor. The allowance will be paid as full compensation for the Contractor's and sub-contractor's extra profit, extra general superintendence, extra field office expense, extra overheads, and all other elements of extra cost not defined herein as actual direct cost.

The actual direct cost shall include only those extra costs for labor and material expended in direct performance of the extra work and may include the following.

- a. The actual payroll cost of all workmen such as laborers, mechanics, craftsmen, and foremen.
- b. The Contractor's or subcontractor's net cost for materials and supplies.
- c. The rental charge for vehicles and construction equipment.
- d. The transportation charges for equipment.
- e. The charges for extra power, fuel, lubricants, water, and special services.
- f. The charges for extra payroll taxes, bond premiums, and insurance premiums.

The form in which actual direct cost records are kept, the construction methods, and the type and quantity of equipment used shall be acceptable to the Engineer.

Construction equipment which the Contractor has on the jobsite and which is of a type and size suitable for use in performing the extra work shall be used. The hourly rental charges for equipment shall not exceed 1/2 percent of the latest applicable monthly rental rates as published by Dataquest Incorporated in its "Rental Rate Blue Book" and shall apply to only the actual time the equipment is used in performing the extra work.

When extra work requires the use of equipment which the Contractor does not have on the jobsite, the Contractor shall obtain the concurrence of the Engineer before renting or otherwise acquiring additional equipment. The rental charges for the additional equipment shall not exceed the latest applicable "Rental Rate Blue Book" published rental rates.

SECTION 1 - GENERAL CONDITIONS

GC.22.1.2 Decreased Price

If a change in the contract price is required due to a modification which decreases the amount of work, such decrease shall not constitute the basis for a claim for damages or anticipated profits on work affected by such decrease. Where the value of omitted work is not covered by applicable unit prices, the Engineer shall determine, on an equitable basis, the amount of:

- a. Credit due the Purchaser for contract work deleted as a result of an authorized change,
- b. Allowance to the Contractor for any actual loss incurred in connection with the purchase, delivery, and subsequent disposal of materials or equipment required for use on the work as planned and which could not be used in any part of the work as actually built, and
- c. Any other adjustment of the contract amount where the method to be used in making such adjustment is not clearly defined in the contract documents.

Unless otherwise agreed upon by the Purchaser and the Contractor, the credit due the Purchaser for reductions in the amount of work to be done shall be the estimated direct cost of the deleted work plus an overhead allowance of the following.

- 10 percent of the estimated direct cost if the work was to have been done by the Contractor's own forces, or
- 15 percent of the estimated direct cost if the work was to have been done by a subcontractor.

Direct cost referred to above shall include the category of costs listed as actual direct costs, Items (a) to (f) inclusive of the article entitled Increased Price.

GC.22.2 Contract Time Changes

The contract time may be changed due to work modifications, hindrances and delays, and work suspensions over which the Contractor has no control.

Contract time will not be changed for delays caused by unfavorable weather or unsuitable ground conditions normally incident to the work, inadequate construction force, failure to place timely orders for equipment and materials, or other causes within the control of the Contractor.

GC.23 Step Dispute Resolution

In the event of any controversy, claim or dispute between the Parties arising out of or relating to this Agreement, including its enforcement, such controversy, claim or dispute, including disputes regarded as such by only one of the Parties, the Parties shall negotiate in good faith to resolve such dispute, including third party mediation, if the Parties so agree.

If no settlement is achieved, either Party may pursue a claim in a federal or state court with competent jurisdiction.

SECTION 1 - GENERAL CONDITIONS

GC.24 Laws and Regulations

The Contractor shall observe and comply with all ordinances, laws, and regulations, and shall protect and indemnify the Purchaser and the Purchaser's officers and agents, including the Engineer, against any claim or liability arising from or based on any violation of the same.

GC.25 Taxes, Permits, and Licenses

The Contractor shall pay all sales, use, and other taxes that are lawfully assessed against the Purchaser or Contractor in connection with the work and shall obtain and pay for all required licenses, permits, and inspections.

The Contractor will be compensated for any increase in tax rates, license fees, and permit fees or any new taxes, licenses, or permits imposed after the date of the Proposal; provided, however, that this provision shall be limited to sales, use, and excise taxes assessed against the completed work and to licenses and permits required specifically for the proposed work.

GC.26 Patents

Royalties and fees for patents covering materials, articles, apparatus, devices, equipment, or processes used in the work shall be included in the contract amount. The Contractor shall satisfy all demands that may be made at any time for such royalties or fees and he shall be liable for any damages or claims for patent infringements. The Contractor shall, at his own cost and expense, defend all suits or proceedings that may be instituted against the Purchaser for alleged infringement of any patents involved in the work and, in case of an award of damages, the Contractor shall pay such award. Final payment to the Contractor by the Purchaser will not be made while any such suit or claim remains unsettled.

GC.27 Materials and Equipment

Unless specifically provided otherwise in each case, all materials and equipment furnished for permanent installation in the work shall conform to applicable standard specifications and shall be new, unused, and undamaged when installed or otherwise incorporated in the work. No such material or equipment shall be used by the Contractor for any purpose other than that intended or specified, unless such use is specifically authorized by the Purchaser in each case.

All required tests in connection with acceptance of source of materials shall be made at the Contractor's expense by a properly equipped laboratory of established reputation whose work and testing facilities are acceptable to the Purchaser. Any change in origin or method of preparation or manufacture of a material being routinely tested will require new tests. Reports of all tests shall be furnished to the Engineer or Purchaser in as many copies as required.

GC.28 Guarantee

The Contractor guarantees that the work herein contracted will be as specified and will be free from defects in design, workmanship, and materials. Contractor does not guarantee or warrant parts subject to normal wear and tear during operation. If within the guarantee period the work fails to meet the provisions of this guarantee, the Contractor shall promptly correct any defects, including nonconformance with the contract documents by adjustment, repair, or replacement of all defective parts or materials at the Contractor's option and expense, after consulting with the Purchaser on the proposed remedy plans.

SECTION 1 - GENERAL CONDITIONS

Except as otherwise prescribed by the terms of any special guarantees required by the contract documents, the guarantee period shall begin on the date of final payment and shall end 12 months later.

The cost of all materials, parts, labor, transportation, supervision, special tools, and supplies required for replacement or repair of parts and for correction of defects shall be paid by the Contractor or by the surety.

This guarantee shall be extended to cover all repairs and replacements furnished under the guarantee and the period of the guarantee for each such repair or replacement shall be 1 year after correction of the defect except as otherwise prescribed by the terms of any special guarantees required by the contract documents.

The Contractor will be given an opportunity to confirm the existence of the defect, but he shall not delay the correction while making such determination.

If within 10 days after the Purchaser has notified the Contractor of a defect, failure, or abnormality in the work, the Contractor has not started to make the necessary repairs or adjustments, the Purchaser is hereby authorized to make the repairs or adjustments or to order the work to be done by a third party; the cost of the work to be paid by the Contractor.

In the event of an emergency where, in the judgment of the Purchaser, delay would cause serious loss or damage, repairs or adjustments may be made by the Purchaser or a third party chosen by the Purchaser without advance notice to the Contractor and the cost of the work shall be paid by the Contractor or by the surety.

GC.29 Contractor's Insurance Coverage

The Contractor shall not commence work under this Contract until Contractor has obtained all the insurance required under this article. Furthermore, the Contractor shall not allow any sub-contractor to commence work under this Contract until the sub-contractor has obtained the same insurance as is required of the Contractor. The sub-contractor alone shall be responsible for the sufficiency of its own insurance program.

GC.29.1 Certificates of Insurance

Certificates of Insurance acceptable to the Purchaser shall be filed with the Purchaser prior to commencement of the work. All insurance carried shall conform to the relevant provisions of the respective Project Documents and be with insurance companies which are rated "A, X" or better by Best's Insurance Guide, or other insurance companies of recognized responsibility satisfactory to the Purchaser.

GC.29.2 Proof of Carriage of Insurance.

Satisfactory certificates of insurance shall be filed with the Purchaser prior to starting any construction work on this contract. The parties agree that the requirements with respect to requirements to procure and maintain insurance under this Section is a material part of this Agreement.

SECTION 1 - GENERAL CONDITIONS

GC.29.3 Additional Insureds

Insurance coverages furnished under this Contract, with the exception of Workers' Compensation and Employer's Liability, shall include the City of Hastings and their members, directors, officers, agents, and employees as named Additional Insureds on a primary and noncontributory basis, and shall include Products and completed operations with respect to the activities of the Contractor and shall be maintained for the full duration of the project including for a period after completion to include the statute of repose.

Notwithstanding any other provision of these policies, the insurance afforded shall apply separately to each insured, with respect to any claim, suit, or judgment made or brought by or for any other insured, as though a separate policy had been issued to each, except the insurer's liability shall not be increased beyond the amount or amounts for which the insurer would have been liable had only one insured been named.

The Purchaser shall not by reason of their inclusion under these policies incur liability to the insurance carrier for payment of premium for these policies.

GC.29.4 Waiver of Subrogation

To the extent permitted by applicable law, the Contractor and their sub-contractor shall require their insurance carriers, with respect to all insurance policies, to waive all rights of subrogation against the Purchaser their partners, directors, officers, agents, and employees.

GC.29.5 Workers' Compensation and Employer's Liability Insurance

The Contractor shall procure, and shall maintain during the life of this Contract, Workers' Compensation Insurance as required by workers' compensation laws of the State of Nebraska and also of the state in which the sub-contractor is domiciled.

The Contractor shall also be protected against claims for injury, disease, or death of employees which, for any reason, may not fall within the provisions of a workers' compensation law. The Employer's Liability Insurance shall contain the following limits of liability:

Bodily Injury by Accident	\$500,000 each accident
Bodily Injury by Disease	\$500,000 each employee
Bodily Injury by Disease	\$500,000 policy limit

GC.29.6 General Liability Insurance

This insurance shall be written per project on an "occurrence" policy form, including coverage for premises/operations, products/completed operations, blanket contractual liability, independent contractors and personal injury, with no exclusions for explosion, sudden and accidental pollution or an absolute or total pollution exclusion, collapse and underground perils. The commercial general liability policy shall also include a severability of interest clause and a cross liability clause in the event more than one entity is "named insured" or "named additional insured" under the liability policy.

Limits of Insurance shall be as follows:

Each Occurrence Limit	\$1,000,000
-----------------------	-------------

SECTION 1 - GENERAL CONDITIONS

Products/Completed Operations	\$2,000,000
General Aggregate Limit	\$2,000,000
Personal and Advertising Injury	\$1,000,000

GC.29.7 Automobile Liability Insurance

This insurance shall be written under a Business Auto Policy and shall protect the Contractor and Additional Insureds against claims arising from injuries to members of the public or damage to property of others arising from the use of automobiles whether such automobiles are owned, non-owned, or hired. Automobile insurance shall include Motor Carrier Endorsement Act MCS 90 and transportation pollution coverage if applicable. If work is being done near a railroad track, the 50' railroad right of way exclusion must be deleted.

Limit of Liability	\$1,000,000 each accident
--------------------	---------------------------

GC.29.8 Umbrella Liability Policy

This insurance shall protect the Contractor and the Additional Insureds against all claims in excess of the limits provided under the employer's liability, automobile liability, and general liability policies. The liability limits of the umbrella liability policy shall be not less than \$5,000,000 per occurrence. This policy shall be an "occurrence" type policy. However, Purchaser reserves the right to require higher limits with respect to each project.

GC.29.9 Pollution Liability – Not Applicable

GC.29.10 Riggers Liability – Applicable

Should work involve the moving, lifting, lowering, rigging or hoisting of property or equipment Contractor shall carry Rigger's Liability Insurance to insure against physical loss or damage to the property or equipment on a Replacement Cost Basis.

GC.29.11 Railroad Protective Liability – Not Applicable

GC.29.12 Professional Liability – Not Applicable

GC.29.13 Transportation Insurance – Not Applicable

GC.29.14 Property Insurance A.K.A. Builder's Risk - Not Applicable

GC.30 Indemnification

To the fullest extent permitted by laws and regulations, the Contractor shall defend, indemnify, and hold harmless the Purchaser, their officers, directors, members, consultants, agents, and employees from and against all claims, damages, losses, and expenses, direct, indirect, or consequential (including but not limited to fees and charges of engineers, architects, attorneys, and other professionals and court and arbitration costs) arising out of or resulting from the negligent, wrongful, or defective performance of the work by the Contractor, any sub-contractor, any person or organization directly or indirectly employed by any of them to perform or furnish any of the work, or anyone for whose acts any of them may be liable, regardless of whether or not it is caused in part by a party indemnified hereunder or arises by or is imposed by law and regulations regardless of the negligence of any such party.

SECTION 1 - GENERAL CONDITIONS

In any and all claims against the Purchaser, or of any of their officers, directors, members, consultants, agents, or employees by any employee of the Contractor, any sub-contractor, any person or organization directly or indirectly employed by any of them to perform or furnish any of the work or anyone for whose acts any of them may be liable, this indemnification obligation shall not be limited in any way by any limitation on the amount or type of damages, compensation, or benefits payable by or for the Contractor or any such sub-contractor or other person or organization under workers' or workmen's compensation acts, disability benefit acts, or other employee benefit acts, nor shall this indemnification obligation be limited in any way by any limitation on the amount or type of insurance coverage provided by the Purchaser, the Contractor, or any of their sub-contractors.

GC.31 Release of Liability

Acceptance by the Contractor of the last payment shall be a release to the Purchaser and every officer and agent thereof, from all claims and liability hereunder for anything done or furnished for, or relating to the work, or for any act or neglect of the Purchaser or of any person relating to or affecting the work.

GC.32 Claims for Labor and Materials

The Contractor shall indemnify and save harmless the Purchaser from all claims for labor and materials furnished under this Contract. When requested by the Purchaser, the Contractor shall submit satisfactory evidence that all persons, firms, or corporations who have done work or furnished materials under this Contract, for which the Purchaser may become legally liable, have been fully paid or satisfactorily secured. In case such evidence is not furnished or is not satisfactory, an amount will be retained from money due the Contractor which, in addition to any other sums that may be retained, will be sufficient, in the opinion of the Purchaser, to liquidate all such claims. Such sum will be retained until the claims as aforesaid are fully settled or satisfactorily secured.

Before final acceptance of the work by the Purchaser, the Contractor shall submit to the Engineer in duplicate a notarized affidavit stating that all subcontractors, vendors, persons, or firms who have furnished labor or materials for the work have been fully paid and that all taxes have been paid. If a performance bond has been executed, a statement from the surety shall also be submitted consenting to the making of the final payment.

GC.33 Final Inspection

When the work has been substantially completed and at a time mutually agreeable to the Purchaser and Contractor, the Purchaser will make a final inspection of the work as to the acceptability and completeness of the work.

GC.34 Payments and Retainage.

The City, at its discretion, may include in such monthly estimates payments for materials that will eventually be incorporated in the project, provided that such materials are suitably stored on the site of the project at the time of preparing estimates for payment. Such payment is to be based upon the estimated value thereof as ascertained by the Engineer. Such material when so paid for by the City shall not be removed from the project without consent of the

SECTION 1 - GENERAL CONDITIONS

City and, in case of default on the part of the Contractor, the City may use or cause to be used by others these materials in construction of the project.

The City will retain five percent (5%) of the total contract amount for all work completed including change orders.

Payment of the retainage will be made within forty-five (45) days after project is substantially complete, provided the Contractor submits a Letter of Credit for 125% of the uncompleted work.

The bid proposal price sheets include any and all work for each project. Any requirement shown in the drawings, but not listed separately in the proposal price sheets, are considered subsidiary to the work. This includes but is not limited to abandonments of existing utilities and any potholing required for utility locates prior to boring.

GC.35 Hazardous Materials

As required under Federal Hazardous Communications Standards and certain state and local laws, the Contractor shall provide Material Safety Data Sheets covering all hazardous materials furnished under or otherwise associated with the work under this Contract. The Contractor shall provide the Purchaser with either copies of the applicable Material Safety Data Sheets or copies of a document certifying that no Material Safety Data Sheets are required under any federal, state, or local law, regulation, statute, or ordinance in effect at the jobsite.

Hazardous materials are defined in the applicable statute which may use the terminology "toxic substances" instead of "hazardous materials." The Contractor is responsible for determining if any substance or material furnished, used, applied, or stored under this Contract is within the provisions of any applicable statute.

If the work under this Contract includes onsite construction or erection, the Contractor shall provide written notice of the presence of hazardous materials to local fire, medical, and law enforcement agencies as required with a copy of such notice to the Purchaser.

The Contractor shall provide labeling of hazardous materials and training of employees in the safe usage of such materials as required under any applicable federal, state, or local law, regulation, statute, or ordinance.

GC.36 Liquidated Damages - Not Applicable

GC.37 Consequential Damages

Except for Supplier's third party obligations arising out of or liability for breach of Articles GC.26 and/or GC.30, Purchaser and Supplier will not be liable to each other for loss of profits, loss of use, loss of contracts, or consequential damages arising out of this Contract. This Section will not relieve Supplier of any obligation under GC.36.

SECTION 1 - GENERAL CONDITIONS

GC.38 Limitation of Liability

With the exception of (a) indemnification stated in Article GC.30 and (b) the insurance coverages and limits set forth in Article GC.29, Supplier's total limit of liability on any claim, whether for breach of Contract, breach of warranty, tort, negligence, strict liability, or any other legal theory, for any loss or damage arising out of or connected to, or resulting from this Contract, shall be limited to the purchase price to be paid by Purchaser.

GC.39 Confidentiality

"Confidential Information" means the confidential or proprietary designs, know-how, processes, trade secrets, and other information owned or controlled by Purchaser, Engineer, or Supplier respectively. Supplier agrees to hold any Confidential Information received in the strictest confidence, shall only use the Confidential Information as necessary to perform the work. Purchaser agrees to hold any Confidential Information received in the strictest confidence and shall only use the confidential information as necessary for engineering, construction, start-up, commissioning, maintenance, or other purposes related to the project. Each party shall use the same degree of care as is used for its own information of similar importance, but no less than reasonable care.

GC.40 Work Eligibility Status

The Contractor is required and hereby agrees to use a federal immigration verification system to determine the work eligibility status of new employees physically performing services within the State of Nebraska. A federal immigration verification system means the electronic verification of the work authorization program authorized by the Illegal Immigration Reform and Immigrant Responsibility Act of 1996, 8 U.S.C. 1324a, known as the E-Verify Program, or an equivalent federal program designated by the United States Department of Homeland Security or other federal agency authorized to verify the work eligibility status of a newly hired employee.

GC.41 Fair Labor Standards

The Contractor agrees to comply with all current applicable State, Federal, and City fair labor standards in the execution of the contract. Pursuant to the Title VI Non-Discrimination Program of the City of Hastings, Contractor agrees to comply with the provisions set forth by CITY's Title VI Non-discrimination Program, if applicable. A copy of said provisions are as follows:

During the performance of this contract, the contractor, for itself, its assignees and successors in interest (hereinafter referred to as the "contractor") agrees as follows:

- (1) Compliance with Regulations: The contractor shall comply with the Regulation relative to nondiscrimination in Federally-assisted programs of the Department of Transportation (hereinafter, "DOT") Title 49, Code of Federal Regulations, Part 21, and the Federal Highway Administration (hereinafter "FHWA") Title 23, Code of Federal Regulations, Part 200 as they may be amended from time to time, (hereinafter referred to as the Regulations), which are herein incorporated by reference and made a part of this contract.
- (2) Nondiscrimination: The Contractor, with regard to the work performed by it during the contract, shall not discriminate on the grounds of race, color, or national origin,

SECTION 1 - GENERAL CONDITIONS

sex, age, and disability/handicap in the selection and retention of subcontractors, including procurements of materials and leases of equipment. The contractor shall not participate either directly or indirectly in the discrimination prohibited by 49 CFR, section 21.5 of the Regulations, including employment practices when the contract covers a program set forth in Appendix B of the Regulations.

- (3) Solicitations for Subcontractors, Including Procurements of Materials and Equipment: In all solicitations either by competitive bidding or negotiation made by the contractor for work to be performed under a subcontract, including procurements of materials or leases of equipment, each potential subcontractor or supplier shall be notified by the contractor of the contractor's obligations under this contract and the Regulations relative to nondiscrimination on the grounds of race, color, or national origin, sex, age, and disability/handicap.
- (4) Information and Reports: The contractor shall provide all information and reports required by the Regulations or directives issued pursuant thereto, and shall permit access to its books, records, accounts, other sources of information, and its facilities as may be determined by the (Recipient) or the FHWA to be pertinent to ascertain compliance with such Regulations, orders and instructions. Where any information required of a contractor is in the exclusive possession of another who fails or refuses to furnish this information the contractor shall so certify to the (Recipient), or the FHWA as appropriate, and shall set forth what efforts it has made to obtain the information.
- (5) Sanctions for Noncompliance: In the event of the contractor's noncompliance with the nondiscrimination provisions of this contract, the (Recipient) shall impose such contract sanctions as it or the FHWA may determine to be appropriate, including, but not limited to:
 - (a.) Withholding of payments to the contractor under the contract until the contractor complies, and/or
 - (b.) Cancellation, termination or suspension of the contract, in whole or in part.
- (6) Incorporation of Provisions: The contractor shall include the provisions of paragraphs (1) through (6) in every subcontract, including procurements of materials and leases of equipment, unless exempt by the Regulations, or directives issued pursuant thereto.

The contractor shall take such action with respect to any subcontract or procurement as the (Recipient) or the FHWA may direct as a means of enforcing such provisions including sanctions for non-compliance: Provided, however, that, in the event a contractor becomes involved in, or is threatened with, litigation with a subcontractor or supplier as a result of such direction, the contractor may request the (Recipient) to enter into such litigation to protect the interests of the (Recipient), and, in addition, the contractor may request the United States to enter into such litigation to protect the interests of the United States.

SECTION 2 - SPECIAL CONDITIONS

SPECIAL CONDITIONS

SC.1 GENERAL. These Special Conditions are nontechnical in nature and shall supplement the General Conditions in the administration and regulation of field construction work performed under these specifications.

SC.2 ENGINEER'S DRAWINGS AND SPECIFICATIONS. After contract award, the Contractor will be furnished two sets of all drawings including revisions thereto and two working copies of the specifications without charge. Additional sets of drawings and revisions thereto and additional copies of specifications may be obtained by payment of printing, handling, and mailing costs. All drawings and specifications shall be returned to the Purchaser upon completion of the work.

SC.3 PROJECT MANAGEMENT. The coordination of all field construction will be under the direction of the Purchaser, who will be responsible for coordinating work between various contractors and for resolving any conflicts between contractors regarding scheduling or coordination.

The time of completion is a basic consideration of this Contract and the Contractor shall be responsible for performing his work in accordance with the specified construction schedule. If at any time the Contractor's work is behind schedule, the Contractor shall increase his forces, work overtime, or otherwise accelerate his operations to comply with the schedule, and shall put into effect definite procedures for getting the work back on schedule. The proposed procedures shall be subject to the Purchaser's acceptance or modification. The procedures adopted shall be put into effect immediately.

The Purchaser will not be responsible for the assignment of personnel, or for obtaining materials or supplies, or for any other services to the Contractor except the coordination of work between contractors and as specifically set forth in the contract documents.

SC.4 CONTRACTOR'S OFFICE AT SITE OF WORK. Not used.

SC.5 FIELD RECORDS. The Contractor shall maintain at the project site an orderly and adequate file of up-to-date copies of all Engineer's drawings and specifications, manufacturer's prints and specifications, and other contract documents and supplementary data.

In addition, the Contractor shall maintain a continuous record of all field changes by means of a set of drawings marked to indicate current "as-built" conditions. This "as-built" set of drawings shall be available for check by the Purchaser in order for him to ascertain that it is being kept current. At the conclusion of the work, the "as-built" drawings and other engineering data, accurately and neatly marked with field changes, shall be submitted to the Purchaser in the required number of copies. The "as-built" drawings and data shall include all revisions to the work made under this Contract, including those made by subcontractors.

SECTION 2 - SPECIAL CONDITIONS

SC.6 CONTRACTOR'S SUPERVISION AT THE SITE. The Contractor shall furnish adequate management, supervisory, and technical personnel on the site to ensure expeditious and competent handling of the work.

A superintendent experienced in construction of the type specified, knowledgeable in the pertinent industry codes and standards, and who is a permanent member of the Contractor's organization, shall be a resident at the project throughout the construction. The superintendent shall be fully authorized to act for the Contractor and to receive whatever orders or notices may be given for the proper prosecution of the work. Contractor shall provide superintendents resume for approval by Owner.

The Contractor's field organization shall include an experienced staff of qualified technical personnel to handle onsite engineering, planning, and direction of all field work.

The Contractor shall be responsible for complete supervision and control of his subcontractors as though they were his own forces. Notice to the Contractor shall be considered notice to any affected subcontractor.

SC.7 SUBCONTRACTS. The Contractor shall perform the majority of the work with his own forces and under the management of his own organization. Specific portions of the work may be subcontracted only by subcontractors who have been listed in the Proposal and who are accepted by the Purchaser as provided in the General Conditions. All subcontractors shall be directly responsible to the Contractor and shall be under his general supervision. All work performed under subcontracts shall be subject to the same contract provisions as the work performed by the Contractor's own forces.

SC.8 RELATIONS WITH OTHER CONTRACTORS. The Contractor shall cooperate with all other contractors who may be performing work in behalf of the Purchaser, and with workmen who may be employed by the Purchaser in the vicinity of the work under this Contract, and he shall conduct his operations to minimize interference with the work of such contractors or workmen. The Contractor shall promptly make good, at his own expense, any injury or damage that may be sustained by other contractors or employees of the Purchaser due to activities associated with this Contract. Any difference or conflict which may arise between the Contractor and other contractor's, or between the Contractor and workmen of the Purchaser, in regard to their work shall be resolved as determined by the Purchaser.

SC.9 ACCEPTANCE OF WORK BY OTHERS. If any part of the Contractor's work is dependent upon the quality and completeness of work performed under another contract, the Contractor shall inspect the other contractor's work and promptly report defects therein which render such work unsuitable for the proper execution of the work under this Contract. Failure to report such defects to the Purchaser shall constitute the Contractor's acceptance of such work as suitable to receive the Contractor's work; provided, however, that the Contractor shall not be responsible for defects which develop after his inspection and which could not have been reasonably detected or foreseen.

SECTION 2 - SPECIAL CONDITIONS

SC.10 METHODS OF FIELD OPERATION. The Contractor shall inform the Purchaser in advance concerning his plans for carrying out each part of the field work. Review by the Purchaser of any plan or method of work proposed by the Contractor shall not relieve the Contractor of any responsibility therefor, and such review shall not be considered as an assumption of any risk or liability by the Purchaser or any officer, agent, or employee thereof. The Contractor shall have no claim because of the failure or inefficiency of any plan or method so reviewed.

Any method of work suggested by the Purchaser, but not specified, shall be used at the risk and responsibility of the Contractor, and the Purchaser will assume no responsibility therefor. The Contractor alone shall be responsible for the safety, adequacy, and efficiency of his construction plant, equipment, and methods.

The Contractor shall be solely and completely responsible for conditions of the jobsite, including safety of all persons and property during performance of the work. This requirement will apply continuously and not be limited to normal working hours. The Purchaser's construction review of the Contractor's performance is intended to include review of the adequacy of the Contractor's safety measures in, on, or near the construction site.

Shutdown of valves or equipment will be made only by Owner's personnel. In the event that an emergency condition warrants, the Contractor shall take direct action to make shutdown, but must notify Owner immediately and remain on worksite to demonstrate what has taken place to Owner's personnel.

SC.11 SAFETY, HEALTH, AND ACCIDENT PREVENTION. The Contractor shall conduct all operations under this Contract in a manner to prevent bodily harm and damage to property. The Contractor shall continuously inspect all operations, work, materials, and equipment; shall conduct health surveys of all work areas; and shall be solely responsible for the discovery, determination, and correction of conditions which constitute a risk of bodily harm or property damage.

The Purchaser will resolve conflicts regarding safety and health measures and practices. The Purchaser will monitor the Contractor's safety and health measures, and may require changes in the Contractor's Safety, Health, and Accident Prevention Program during the performance of the work.

The Contractor shall implement and maintain a written Safety, Health, and Accident Prevention Program specifically applicable to the work. The Contractor's program shall meet the requirements of the codes and regulations of federal, state, local, and other authorities having jurisdiction over this work. The Contractor's Safety, Health, and Accident Prevention Program shall include disciplinary procedures and safety orientation training procedures applicable to Contractor and subcontractor personnel.

The Contractor's Safety, Health, and Accident Prevention Program shall include equipment to be used, sampling strategy and calculations, methods of compliance, and personnel protective equipment. The calibration, sampling, and analytical laboratory procedures used shall be in conformance with OSHA's Industrial Hygiene Field Operations Manual.

SECTION 2 - SPECIAL CONDITIONS

The Contractor's Safety, Health, and Accident Prevention Program shall be submitted for review by the Purchaser 30 days prior to the start of the work at the project site. This review will not relieve the Contractor of his responsibility for safety and health, nor shall such review be construed as limiting in any manner the Contractor's obligation to undertake any action which may be necessary or required to establish and maintain safe working conditions respecting his work at the project site. The Purchaser reserves the right to require the Contractor to modify any portion of his Safety, Health, and Accident Prevention Program.

The Contractor shall immediately correct any unsafe conditions identified by the Purchaser. In the event the Contractor fails to immediately correct such unsafe conditions, the Purchaser may either have the unsafe conditions corrected by others at the Contractor's expense, or direct that the work be stopped in the area of the unsafe condition; however, this right to stop the work shall not give rise to any duty on the part of the Purchaser to exercise this right.

The Contractor shall appoint a qualified Safety and Health Representative. The Safety and Health Representative shall attend all project safety and health meetings. The Contractor's Safety and Health Representative shall have the authority to have unsafe conditions corrected and direct that the work be stopped in the area of the unsafe condition, if deemed necessary.

The Contractor shall maintain accurate accident and injury reports.

The Contractor shall hold regular scheduled meetings to instruct his personnel and his subcontractors' personnel in safety and health practices. The Contractor shall furnish safety and health equipment and enforce the use of such equipment by his employees and the employees of his subcontractors.

The Contractor waives the right to bring claim for damages against the Purchaser or Engineer for any cause whatsoever because of any action taken or not taken including but not limited to the correction of unsafe conditions or work stoppages in connection with the Contractor's Safety, Health, and Accident Prevention Program or such program of another contractor. If such a claim against the Purchaser or Engineer is brought by a third party, the Contractor shall indemnify and defend the Purchaser or Engineer against such claim in accordance with the General Conditions article entitled INDEMNIFICATION.

SC.12 FALL PROTECTION. The OSHA Fall Protection Standard 29 CFR 1926 Subpart M shall be strictly adhered to by the Contractor. Fall protection is required for all of Contractor's Work operations one hundred percent of the time, whether climbing, traveling, or working. **No Work operation is exempt from the six (6) foot fall protection requirement.**

Fall protection body harnesses, lanyards, and lifelines shall be used in accordance with OSHA Standard 1926 Subpart 502D, with the following exceptions:

Full body harnesses shall be used in lieu of safety belts.

SECTION 2 - SPECIAL CONDITIONS

Only lanyards with shock absorbers and locking type snap hooks shall be used.

At least two lanyards shall be used to provide one hundred percent fall protection when moving around obstructions, connection points, or other similar items.

Fall protection guardrail systems shall comply with OSHA Standard 1926 Subpart 502(b) except manila, plastic, or synthetic rope shall not be used as guardrails.

Contractor shall provide his own confined space equipment, monitors, and personnel for hole watches.

SC.13 LINES AND GRADES.

Not used

SC.14 PRESERVATION OF MONUMENTS AND STAKES.

Not used

SC.15 PROTECTION OF PROPERTY AND PUBLIC LIABILITY. The Contractor shall be accountable for any damages resulting from his operations. He shall be fully responsible for the protection of all persons including members of the public, employees of the Purchaser, employees of the Engineer, and employees of other contractors or subcontractors, and all public and private property including structures, sewers, and utilities above and below ground.

The Contractor shall furnish and maintain all necessary safety equipment, such as barriers, signs, warning lights, and guards, to provide adequate protection of persons and property.

The Contractor shall give reasonable notice to the owners of public or private property and utilities when such property and utilities are liable to injury or damage through the performance of the work and shall make all necessary arrangements with such owners relative to the removal and replacement or protection of such property or utilities.

SC.16 EMERGENCY PROTECTION. Whenever, in the opinion of the Purchaser, the Contractor has not taken sufficient precaution for the safety of the public or the protection of the work to be constructed under this Contract or of adjacent structures or property, and whenever, in the opinion of the Purchaser, an emergency has arisen and immediate action is considered necessary, then the Purchaser, with or without notice to the Contractor, may provide suitable protection by causing work to be done and material to be furnished and placed. The cost of such work and material shall be borne by the Contractor, and if the same is not paid on presentation of the bills therefor, such costs may be deducted from any amounts due or to become due the Contractor. The performance of such emergency work shall not relieve the Contractor of responsibility for any damage which may occur.

SECTION 2 - SPECIAL CONDITIONS

SC.17 LOSSES FROM NATURAL CAUSES. All loss or damage arising out of the nature of the work, or from the action of the elements, or from floods or overflows, or from ground water, or from any unusual obstruction or difficulty, or any other natural or existing circumstance either known or unforeseen which may be encountered in the prosecution of the work, shall be sustained and borne by the Contractor at his own cost and expense.

SC.18 QUALIFICATIONS OF WORKMEN. The Contractor shall employ only workmen who are competent to perform the work assigned to them and, in the case of skilled labor, who are adequately trained and experienced in their respective trades and who do satisfactory work.

SC.19 SUNDAY, HOLIDAY, AND NIGHT WORK.

Not used.

SC.20 UNFAVORABLE CONSTRUCTION CONDITIONS.

Not used.

SC.21 REJECTED WORK AND MATERIALS. The Contractor, upon written notice from the Purchaser, shall remove from the premises all work and materials rejected as defective, unsound, improper, or in any way failing to conform to the requirements of the contract documents. The Contractor shall at his sole expense make good all work damaged by such removal and shall promptly replace materials damaged or improperly worked by him and re-execute his own work in accordance with the contract. This includes re-executing or replacing the work of any other contractor that is in any way affected by the removal of the defective work. The obligations of the Contractor under this article shall not extend to defective materials or equipment supplied by the Purchaser, if any.

If the Contractor does not remove his rejected work and materials within 10 days after written notice, the Purchaser may remove and replace such work and materials at the expense of the Contractor.

SC.22 PLACING WORK IN SERVICE. If desired by the Purchaser, portions of the work may be placed in service when completed and the Contractor shall provide proper access for this purpose. Such use and operation shall not constitute an acceptance of the work, and the Contractor shall be liable for defects due to faulty construction throughout the duration of this Contract and thereafter as provided under the "Guarantee" provisions of the General Conditions.

SC.23 CLEANLINESS. The Contractor shall give special attention to keeping the worksite clean and free from trash and debris.

Trash, debris, and waste materials shall not be allowed to accumulate, but shall be removed from the site and disposed of by and at the Contractor's expense. No on site burning shall be allowed.

SECTION 2 - SPECIAL CONDITIONS

Promptly upon completion of the construction work, all Contractor-owned facilities, materials, and construction plant shall be removed from the site. All surfaces damaged by deposits of foreign materials such as oil, grease, weld spatter, and paint shall be restored to their original conditions.

SC.24 PURCHASE ORDERS. Submittal of purchase orders shall not be required.

SC.25 FIRE PROTECTION. Only work procedures which minimize fire hazards to the extent practicable shall be used. Combustible debris and waste materials shall be collected and removed from the site each day, as provided under CLEANLINESS. Fuels, solvents, and other volatile or flammable materials shall be stored away from the construction and storage areas in well marked, safe containers. Good housekeeping is essential to fire prevention and shall be practiced by the Contractor throughout the construction period. The Contractor shall follow the recommendations of the AGC "Manual of Accident Prevention in Construction" regarding fire hazards and prevention.

The Contractor alone shall be responsible for providing adequate fire protection. Failure of the Contractor to comply with or the Purchaser to enforce, the above requirements shall not relieve the Contractor from any responsibility or obligation under this Contract.

The Contractor shall use and abide by Purchaser's hot work permit procedures.

SC.26 SECURITY. The Contractor shall be responsible for all materials and equipment in his custody or placed in construction by him. Security methods shall be employed as required to ensure the protection of all materials, equipment, and construction work from theft, vandalism, fire, and all other damage and loss.

The Contractor shall cooperate with the Purchaser regarding all security measures instituted at the jobsite.

SC.27 PROTECTION OF WORK. The Contractor shall be solely responsible for the protection of his work until its final acceptance by the Purchaser.

The Contractor shall have no claim against the Purchaser or the Engineer because of any damage or loss to the Contractor's work and shall be responsible for the complete restoration of damaged work to its original condition complying with the contract documents.

In the event the Contractor's work is damaged by another party not under his supervision or control, the Contractor shall make his claim directly with the party involved. If a conflict or disagreement develops between the Contractor and one of the other contractors concerning the responsibility for damage or loss to the Contractor's work, the conflict shall be resolved as provided under RELATIONS WITH OTHER CONTRACTORS. Such conflict shall not be cause for delay in the restoration of the damaged work. The Contractor shall restore the work immediately and the cost thereof will be assigned pending the resolution of the conflict.

SECTION 2 - SPECIAL CONDITIONS

SC.28 PROTECTION OF CONCRETE SURFACES. Concrete floors and other concrete surfaces shall be protected from chipping, gouging, scratching, staining, and other damage. Damaged sections shall be repaired or removed and replaced subject to the Purchaser's discretion and acceptance.

Heavy planks and mats shall be placed under equipment and materials being stored, moved, assembled, or installed on or above concrete floor surfaces. Nonflammable, oil-resistant coverings shall be used to protect concrete surfaces from staining.

SC.29 PROTECTION OF ELECTRICAL RACEWAY, CABLE, AND LIGHTING FIXTURES. The Contractor shall protect electrical raceway, cable, lighting fixtures, and associated support systems against damage from movement of equipment and materials, welding, flame cutting, and other construction damage. Raceway and supporting structures for raceway and lighting fixtures shall not be used as access scaffolding at any time. Whenever welding or flame cutting operations occur above or near raceways, cables, or lighting fixtures not shielded from such operations by protective covers, the Contractor shall protect the raceways, cables, and lighting fixtures from damage by means of fire-resistant boards or blankets. Damaged materials shall be repaired or replaced subject to the Purchaser's discretion and acceptance.

Where concrete is removed, or holes are filled, the surrounding equipment shall be protected from concrete, water and dust. Where concrete is removed, dust shall be collected.

SC.30 REPAIR OF DAMAGES. The Contractor shall immediately repair any damage which results from this construction or abnormal use, including damage done to the existing facilities. All such repair work shall be acceptable to the Purchaser.

SC.31 INDEPENDENT TESTING LABORATORY. Not Used

SC.32 COOPERATION WITH THE PURCHASER. The performance of construction work which affects the operation of the Purchaser's system facilities shall be scheduled to be performed only at times acceptable to the Purchaser.

In the event that it is necessary to interrupt the Purchaser's operations or the power supply or to impose abnormal operating conditions on the Purchaser's utility system, such procedure must be acceptable to the Purchaser and a complete understanding and agreement must be reached by all parties concerned well in advance of the time scheduled for such operation, and such understanding shall be definite as to date, time of day, and length of time required. All work shall be scheduled to suit the Purchaser's convenience, taking into consideration the facilities and requirements at all times during construction. The Contractor shall perform work which affects the Purchaser's system facilities at times other than regular working hours if required.

SC.33 MINOR DEFECTS. The Contractor shall readjust, straighten, and repair minor defects and fabrication errors which are normally encountered in the Purchaser-furnished equipment and materials. No claims for extra compensation in connection with such work will

SECTION 2 - SPECIAL CONDITIONS

be considered unless the claim is made in accordance with the applicable provisions in the General Conditions.

When field labor is needed to correct significant errors in the Purchaser-furnished equipment and materials, the Contractor shall furnish such labor when so requested by the manufacturer or by the Purchaser with the consent of the manufacturer. Such labor shall not be included in this Contract, and the Contractor shall obtain payment for the labor from the manufacturer.

SC.34 CHECKOUT AND INITIAL OPERATION. The Contractor shall render all services and do all work required to place each item of equipment installed by him, including all auxiliaries, piping, and wiring, in operating condition to the satisfaction of the Purchaser. Individual systems and items of equipment shall be completed in a sequence that will permit systematic checkout and trial operation of each such component before it is incorporated in the initial operation.

The Purchaser will furnish operating personnel during checkout and initial operation.

It is anticipated that the startup testing and initial operation will be in progress over extended periods of time.

All regular and overtime payrolls and all other contingencies in connection with the checkout and initial operation of equipment shall be included as a part of the lump sum contract price.

SC.35 CONSTRUCTION PLANT AND TEMPORARY FACILITIES. Temporary facilities are defined in Section 3 General Description and Scope of Work

SC.36 RECEIVING, HANDLING, AND STORAGE. Responsibilities for receiving, handling, and storage are defined in Section 3 General Description and Scope of Work.

SC.37 EQUIVALENT MATERIALS AND EQUIPMENT. Whenever a material or article is specified or described by using the name of a proprietary product or the name of a particular manufacturer or vendor, the specific item mentioned shall be understood as establishing the type, function, and quality desired. Other manufacturers' products will be accepted provided sufficient information is submitted to allow the Engineer to determine that the products proposed are equivalent to those named.

Requests for review of equivalency will not be accepted from anyone except the Contractor and such requests will not be considered until after the contract has been awarded.

SC.38 RIGHTS-OF-WAY.

Not used.

SC.38.1 ON PRIVATE PROPERTY.

Not used.

SECTION 2 - SPECIAL CONDITIONS

SC.39 FENCES.

Not used.

SC.40 PROTECTION OF PUBLIC AND PRIVATE PROPERTY.

Not used.

SC.41 MAINTENANCE OF TRAFFIC.

Not used.

SC.42 BARRICADES AND LIGHTS.

Not used.

SC.43 UNDERGROUND INSTALLATIONS

Not used.

SC.44 LAND FOR CONSTRUCTION PURPOSES.

Not used.

SC.45 ENERGIZED FACILITIES. Existing transmission lines, substations, distribution lines, utility lines, telephone lines and other power and signal service lines will be encountered on the site of the work. These service systems will remain energized and functional during construction.

Temporary outages required by the Contactor to perform certain construction activities will be provided by the Purchaser. The Contractor shall give written notice to the Purchaser a minimum of seven days in advance of any requested outages. The Contractor shall recognize that certain outage restrictions may apply that will not allow for an outage, as requested. The Contractor's proposed schedule shall account for these outage restrictions. No extension of time or any additional compensation will be given for these outage restrictions.

The Contractor shall be completely responsible for the safety and protection of his personnel and the public on the site of the work and shall employ all methods necessary to achieve such safety and also assure continuity of all service systems encountered. These methods shall include, but not be limited to, providing barriers, guard structures, insulating guards and sleeves, warning signs, and prevention of unauthorized access to substations.

SC.46 ARTIFACTS.

Not used.

SECTION 2 - SPECIAL CONDITIONS

SC.47 FINAL CLEANUP AND GRADING.

Not used.

SC.48 DUST CONTROL.

Not used.

SECTION 3 GENERAL DESCRIPTION AND SCOPE OF WORK

SECTION 3-0 GENERAL DESCRIPTION AND SCOPE OF WORK

3.001 General. City of Hastings is accepting bids for the construction of two new platforms at the boilerfronts of Units 4 and 5, located at the North Denver Station, 1228 North Denver Street in Hastings, Nebraska.

The bidder is encouraged to visit the site prior to submitting a bid. The Bidder shall inform himself of all conditions and factors which would affect the execution of the work. No claims for financial compensation or time extension, based on the lack of such prior information (or its effect on the cost of the work) will be permitted by the Owner. Please contact Carson Moritz, at 402-462-3678, if you would like to set up a site visit.

The Owner is recommending that the Bidder provide plenty of time for the bid packages to arrive. There have been multiple bids recently that were not delivered on time due to the shipping companies’ delays. Please ensure the bids are mailed with adequate time. They will be promptly opened at 1:30pm on the bid opening day, and late bids cannot be considered.

3.002 Project Schedule. Contractor shall include a proposed schedule with the completion of various activities in accordance with the milestone time periods and dates listed.

Activity	Proposed Date
Contract award date	May 28, 2025
Completed Unit 4 Boilerfront Platform	
Completed Unit 5 Boilerfront Platform	

3.003 Scope. The Contractor shall provide all labor, tools, and materials necessary to complete the following scope of work in the allot time frame.

Fabricate and Install Unit 4 Boilerfront Platform:

- Demo existing platform on west end of Unit 4 furnace.
- Fabricate new platform according to the specifications and drawings attached to this bid.
- Fabricate and install two new access ladders per attached drawings. The access ladders shall have anti-slip rungs and swing assisted ladder gates.
- Paint new steel to match existing steel.

Fabricate and Install Unit 5 Boilerfront Platform:

- Fabricate new platform according to the specifications and drawings attached to this bid.
- Tie into existing platform.

SECTION 3 GENERAL DESCRIPTION AND SCOPE OF WORK

- Paint new steel to match existing steel.
- Owner to relocate existing steam line (not shown on drawings)

3.005 Drawings and Supporting Information. The Owner has provided all the drawings and information available in Appendix A. If additional specific information is necessary, and is not included in the attached drawings, Bidder should request this information from the Owner and efforts will be made to provide additional information.

3.006 Work Not Included Under These Specifications:

- A. Owner to provide Lock Out Tag Out and Hotwork Permits.
- B. Owner to relocate conduit as required.
- C. On request, owner can provide forklift to unload tools.

Sheet Size: ANSID (22.0 x 34.00 INCHES)

GOVERNING CODES:

2018 INTERNATION BUILDING CODE
ASCE 7-16
ACI 318-14 (CAST-IN-PLACE CONCRETE)
AISC 14TH EDITION (STRUCTURAL STEEL)

DESIGN LOADS:

BUILDING CATEGORY = ESSENTIAL FACILITY.....IV
FLOOR LOAD

UTILITY PLATFORM
DL (1-1/2" METAL GRATING (73psf) + 10PSF MEP + 5PSF MISC.)15psf
LL100psf

SEISMIC LOADS

SITE CLASSIFICATION..... D
IMPORTANCE FACTOR (Ie)..... 1.0
SEISMIC USE GROUP..... II
SEISMIC DESIGN CATEGORY..... B
SPECTRAL REPNSE COEFFICIENTS
Ss = 0.077
S1 = 0.041
Sds = 0.083
Sd1 = 0.065

STRUCTURAL STEEL

- FABRICATION AND ERECTION OF STRUCTURAL STEEL TO FOLLOW THE LATEST ADDITION OF AISC SPECIFICATIONS FOR DESIGN, FABRICATION AND ERECTION OF STRUCTURAL STEEL FOR BUILDINGS.
- STRUCTURAL SHAPES TO BE OF MATERIAL SHOWN:
 - WIDE FLANGE (W) SHAPES.....ASTM-A992 (Fy=50ksi)
 - PLATES (PL), CHANNELS (C, MC), ANGLES (L).....ASTM-A36 (Fy=36ksi)
 - RECT./SQUARE TUBES (HSS).....ASTM-A500, GRADE B or C (Fy=46ksi)
 - BOLTS (UNLESS NOTED OTHERWISE).....ASTM-A325
 - ANCHOR RODS.....ASTM-F1554, GRADE 36
 - WELDING ELECTRODES.....ASTM-A233, E70 SERIES HOT-DIPPED GALVANIZED
 - WELDED REINFORCING.....ASTM-A706 (Fy=60ksi)
 - EXPANSION BOLTS.....HILTI KWIK BOLT 3 OR APPROVED EQUIVALENT
 - EPOXY/ADHESIVE ANCHORS (CONCRETE).....HILTI HIT HY 200 OR APPROVED EQUIVALENT
 - SLEEVE ANCHORS.....HILTI HLC OR APPROVED EQUIVALENT
- ALL WELDING TO BE PERFORMED BY CERTIFIED WELDERS AND TO BE IN CONFORMANCE WITH AMERICAN WELDING SOCIETY D1.1 LATEST EDITION.
- ALL BOLTED CONNECTIONS TO BE INSTALLED AND SUPPLIED PER THE R.C.S.C. SPECIFICATION FOR STRUCTURAL JOISTS USING A325 OR ASTM-4490 HIGH STRENGTH BOLTS.
- FIELD AND SHOP BOLTED CONNECTIONS TO BE SNUG-TIGHT CONNECTIONS UNLESS OTHERWISE NOTED.
- ALL CONNECTIONS TO BE DESIGNED BY THE SUPPLIER BASED UPON MAXIMUM BEAM REACTIONS UNLESS NOTED OTHERWISE ON THE DRAWINGS.
- STEEL SUPPLIER TO PAINT/TOUCH UP ALL EXPOSED STEEL PER AISC SPECIFICATION (SECTION 1.24)
- ALL STEEL TO BE SHOP PRIMED WITH FABRICATORS STANDARD NON-ASPHALTIC, LEAD AND CHROMATE FREE, RUST-INHIBITING PRIMER UNLESS OTHERWISE NOTED.
- ALL EXPOSED EXTERIOR STEEL TO BE HOT-DIPPED GALVANIZED.
- ANCHOR ROD HOLES MAY BE OVER SIZED PER TABLE 14.2 OF THE 15TH EDITION OF THE STEEL CONSTRUCTION MANUAL.
- REVIEW AND APPROVAL OF SHOP DRAWINGS BY ENGINEER OF RECORD FOR ALL STEEL MEMBERS IS REQUIRED PRIOR TO FABRICATION. SHOP DRAWINGS TO DETAIL MEMBER SIZE, LENGTH AND REQUIRED CONNECTION INFORMATION.

SHOP DRAWINGS:

SHOP DRAWINGS TO BE SUPPLIED TO THE ARCHITECT AND ENGINEER OF RECORD FOR REVIEW.
SHOP DRAWINGS ARE REQUIRED FOR THE FOLLOWING ITEMS:

ITEM	P.E. SEALED
1. STRUCTURAL STEEL	P.E. SEAL NOT REQ'D

SHOP DRAWINGS TO INCLUDE BUT NOT BE LIMITED TO: LAYOUT, SIZE, ORIENTATION, LENGTHS, THICKNESS, LAPS, EMBEDMENT, MATERIAL STRENGTH, QUANTITY, SPACING, DETAILED CONNECTIONS, CALCULATIONS, EMBEDDED PLATES, ETC.

GENERAL

- FOR FIELD LAYOUT AND SHOP DETAILING, THE CONTRACTOR MUST VERIFY AND COORDINATE DIMENSIONS ON ARCHITECTURAL, MECHANICAL AND STRUCTURAL DRAWINGS AND IMMEDIATELY REPORT ANY DISCREPANCIES IN WRITING TO THE ARCHITECT AND ENGINEER OF RECORD. CONTRACTOR MUST VERIFY ALL EXISTING DIMENSIONS AND CONDITIONS.
- IN NO CASE SHALL DIMENSIONS BE SCALED FROM PLANS, SECTIONS OR DETAILS ON THE STRUCTURAL DRAWINGS.
- THE GENERAL CONTRACTOR SHALL REPORT ALL NON-CONFORMING TEST REPORTS TO THE ENGINEER OF RECORD FOR REVIEW BEFORE PROCEEDING.
- THE CONTRACTOR IS RESPONSIBLE FOR BRACING ALL STRUCTURAL ELEMENTS, WITHOUT OVERSTRESSING, AS REQUIRED UNTIL PROJECT IS COMPLETE.
- WRITTEN CLARIFICATION IS TO BE OBTAINED FROM THE STRUCTURAL ENGINEER FOR ANY DISCREPANCIES BETWEEN THE STRUCTURAL DRAWINGS AND THE PROJECT SPECIFICATIONS. WHERE SUCH CLARIFICATION IS NEITHER REQUESTED NOR PROVIDED, THE MORE COSTLY CONDITION SHALL BE ASSUMED BY THE CONTRACTOR. IF CLARIFICATION IS NOT OBTAINED, THE MORE RESTRICTIVE AND COSTLY CONDITION SHALL BE ASSUMED BY THE CONTRACTOR.
- SEE THE AISC CODE OF STANDARD PRACTICE FOR BUILDINGS AND BRIDGES SECTION 4.3 FOR ELECTRONIC DATA INTERCHANGE PRACTICES, PROCEDURES, AND LIABILITIES, WHERE SUCH DATA INTERCHANGE OCCUR.



JEO CONSULTING GROUP

1937 N CHESTNUT ST
WAHOO, NE 68066
800.723.8567 | jeo.com

JEO Consulting, Inc.
Organization Certificate of
Authorization Number: CA-0069



ISSUE

MARK	DATE	DESCRIPTION
------	------	-------------

HASTINGS NORTH DENVER STATION - UNIT 4 & 5 PLATFORM DESIGN

HASTINGS UTILITIES
1228 NORTH DENVER AVENUE
HASTINGS, NE 68901

JEO Project No:	242382.20
Date:	03.28.2025
QAQC:	SWA
Drawn By:	DEC
Additional Data 1:	
Additional Data 2:	



GENERAL NOTES

J:\Projects\242382.00-Hastings-NDS Platform Design\11 Structural\01 - CAD\IS-NDS PLATFORM DESIGN_242382_10.rvt

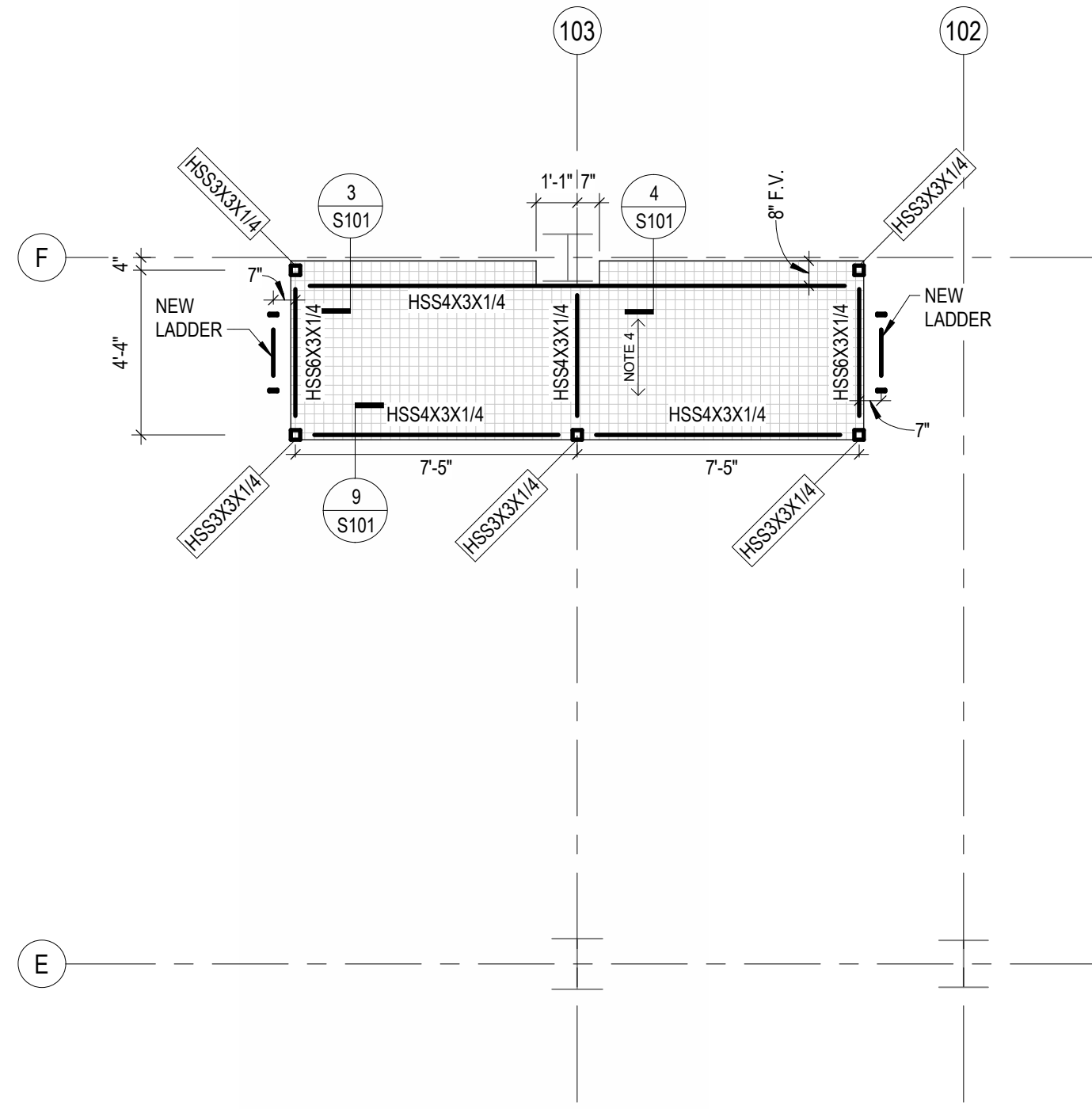

- PLAN NOTES:**
1. FINISH FLOOR ELEVATION = 106'-8" UNLESS INDICATED BY A (+/-) FROM THIS ELEVATION.
 2. TOP OF STEEL ELEVATION = 106'-6 1/2" U.N.O.
 3. EXISTING FINISHED FLOOR ELEVATION = 106'-8".
 4. 19-W-4 1-1/2" X 3/16" GALVANIZED STEEL GRATING, BANDED. GRATING SHALL BE TRU-WELD OR EQUIVALENT.
 5. CONTRACTOR SHALL VERIFY ALL EXISTING DIMENSIONS AND ELEVATIONS.
 6. EXISTING CONDUITS TO BE RELOCATED AS REQUIRED BY HASTINGS UTILITIES.
 7. ALL STEEL IS TO BE PAINTED TO MATCH EXISTING STEEL.
 8. F.V. = FIELD VERIFY.

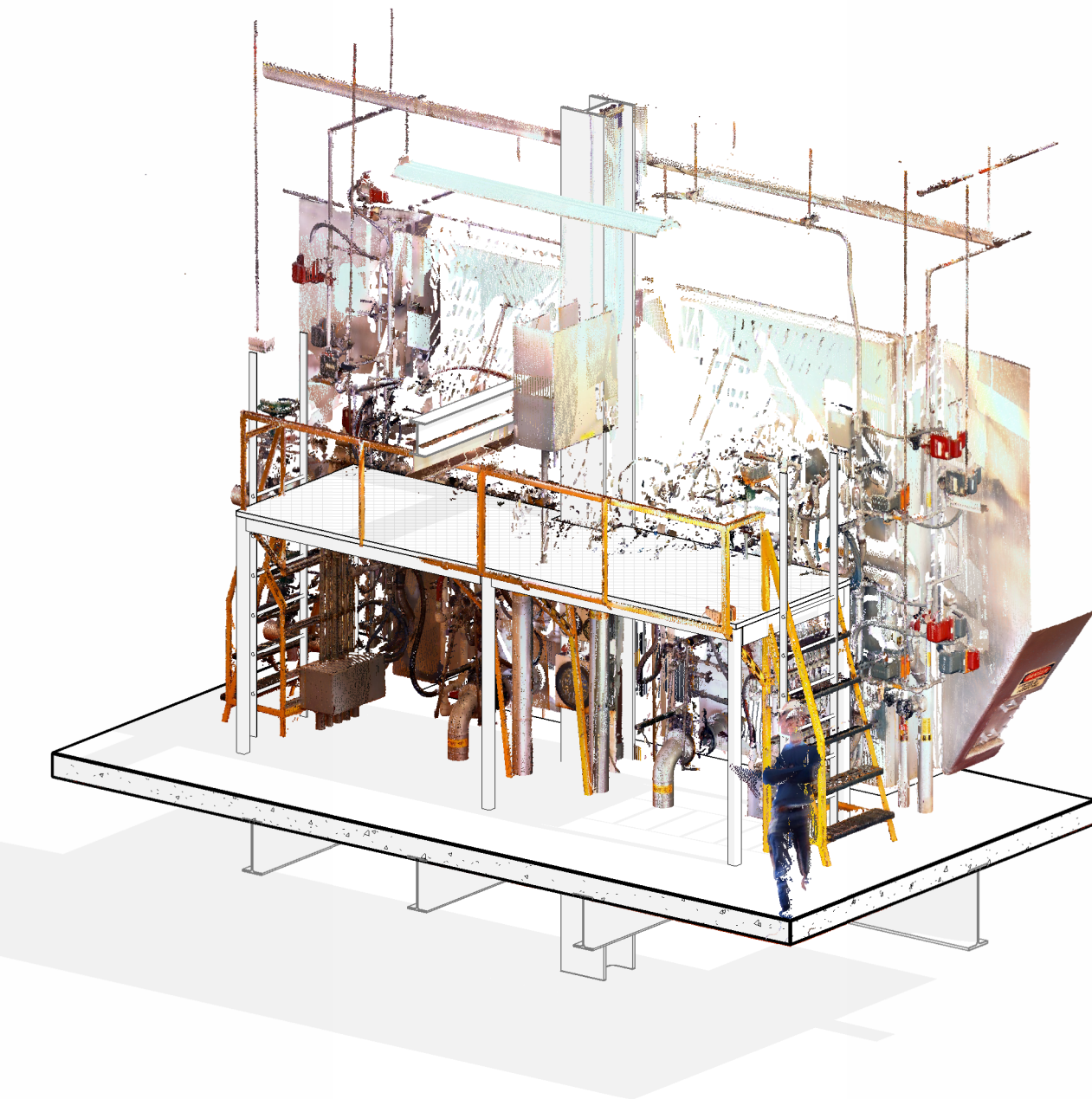

3D UNIT 4 PLATFORM

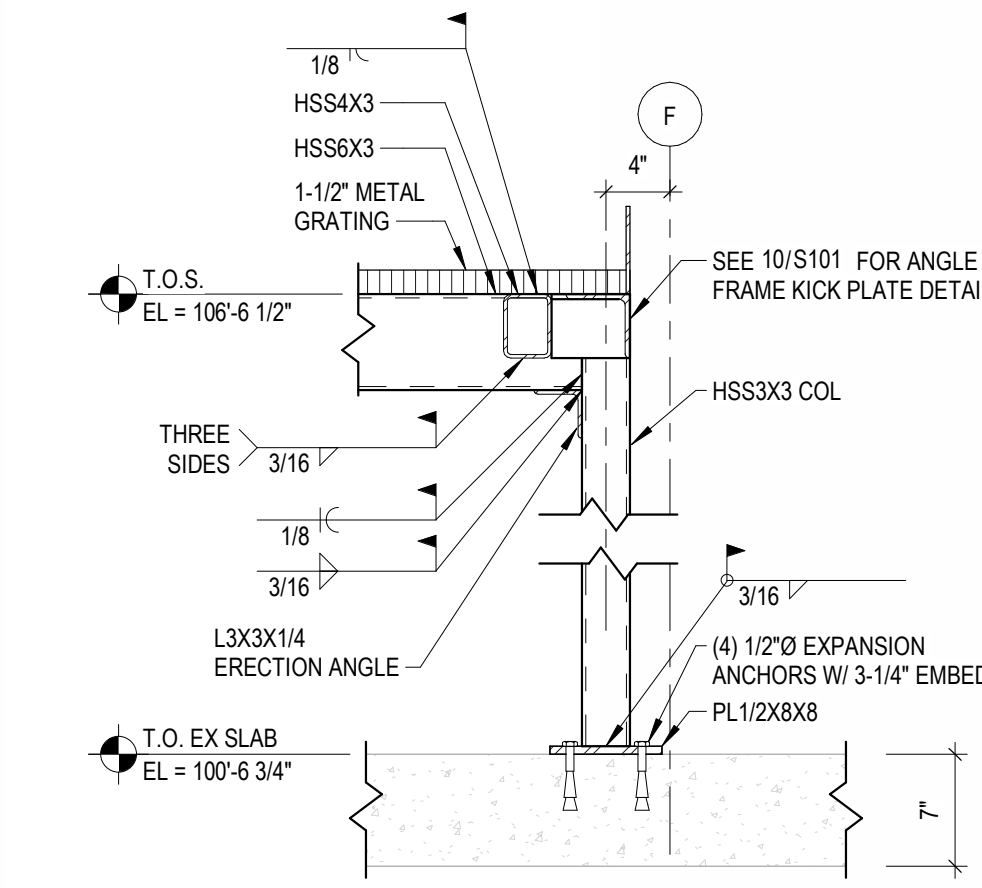

3 UNIT 4 FRAMING DETAIL
1" = 1'-0"

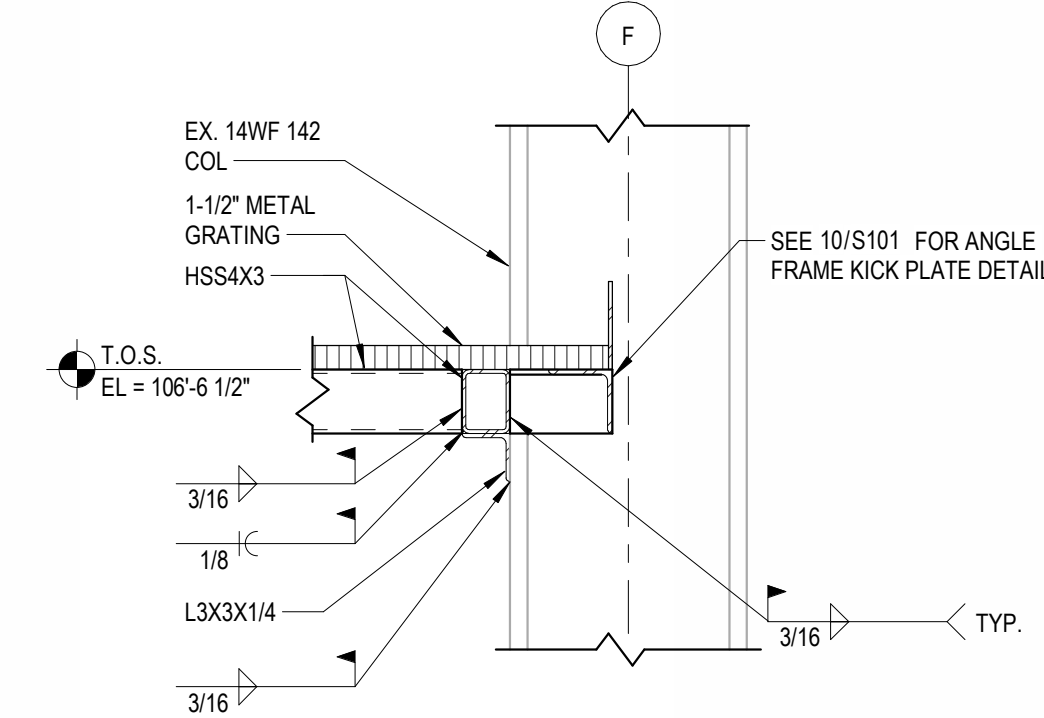

4 UNIT 4 COLUMN DETAIL
1" = 1'-0"

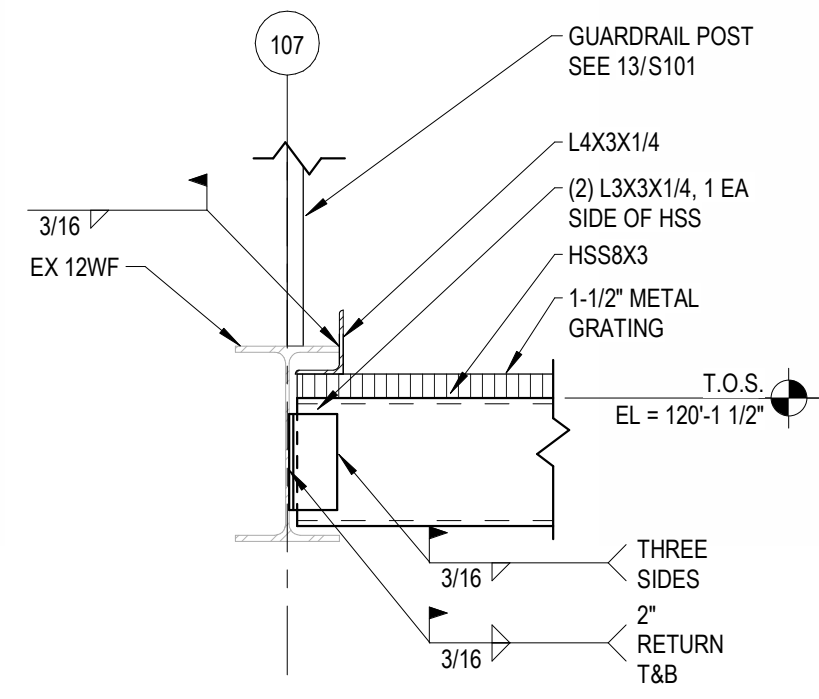

5 UNIT 5 FRAMING DETAIL
1" = 1'-0"

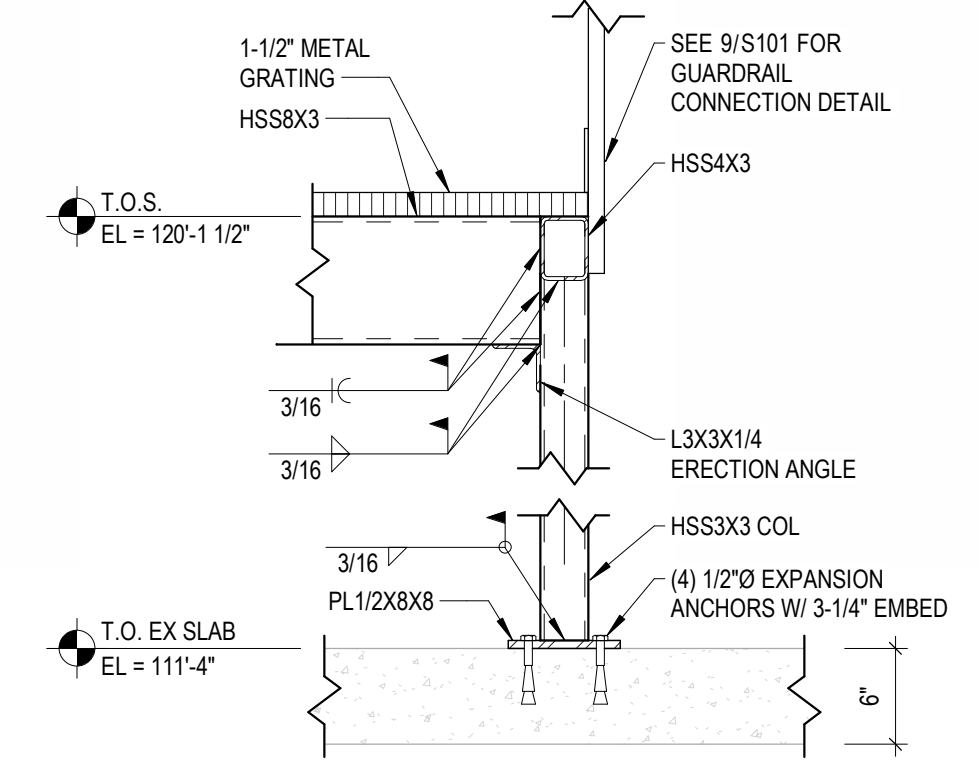

6 UNIT 5 FRAMING DETAIL
1" = 1'-0"

1 UNIT 4 PLATFORM FRAMING PLAN
1/4" = 1'-0"

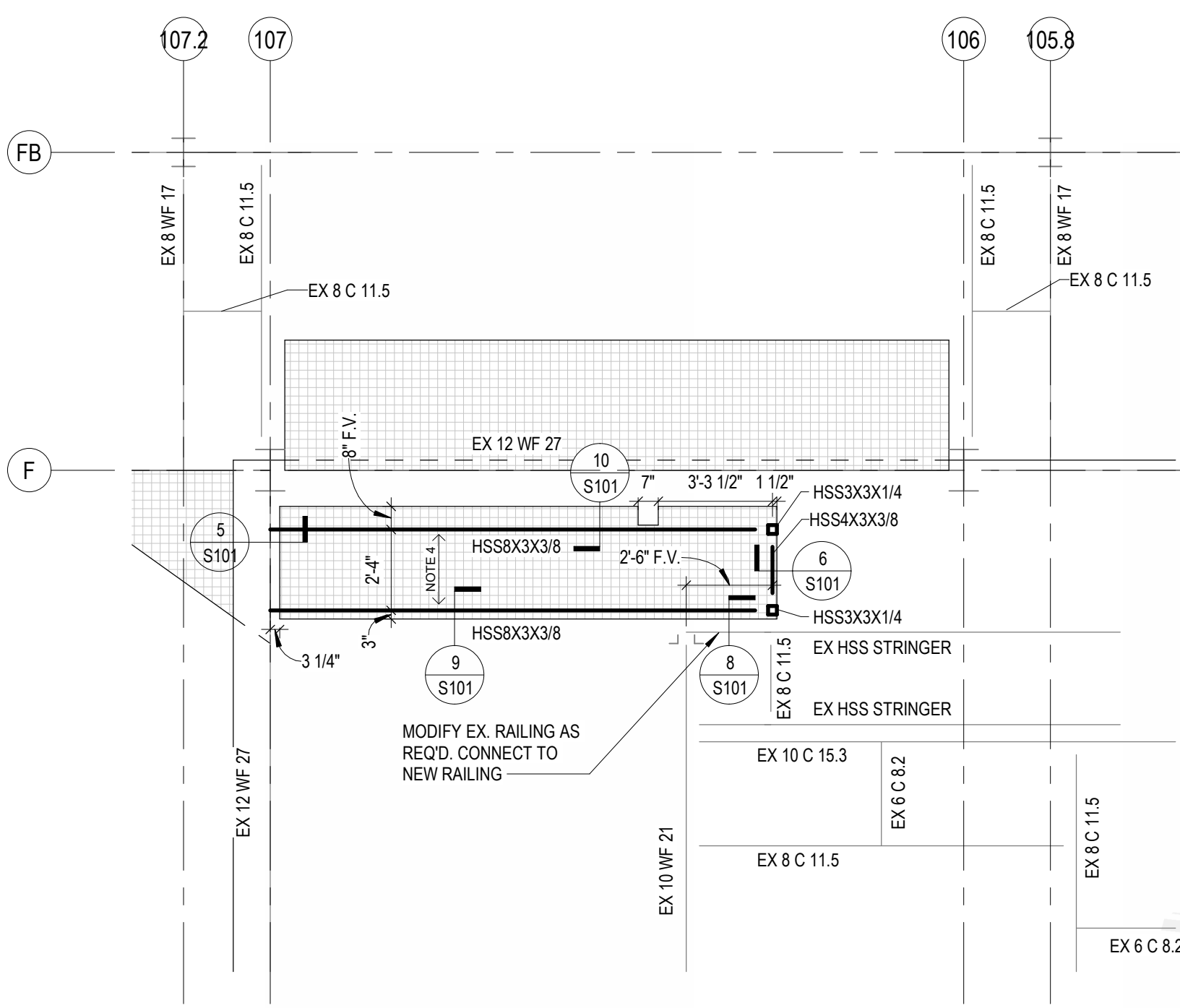

- PLAN NOTES:**
1. FINISH FLOOR ELEVATION = 120'-3" UNLESS INDICATED BY A (+/-) FROM THIS ELEVATION.
 2. TOP OF STEEL ELEVATION = 120'-1 1/2" U.N.O.
 3. EXISTING FINISHED FLOOR ELEVATION = 120'-6".
 4. 19-W-4 1-1/2" X 3/16" GALVANIZED STEEL GRATING, BANDED. GRATING SHALL BE TRU-WELD OR EQUIVALENT.
 5. CONTRACTOR SHALL VERIFY ALL EXISTING DIMENSIONS AND ELEVATIONS.
 6. EXISTING CONDUITS TO BE RELOCATED AS REQUIRED BY HASTINGS UTILITIES.
 7. ALL STEEL IS TO BE PAINTED TO MATCH EXISTING STEEL.
 8. F.V. = FIELD VERIFY.

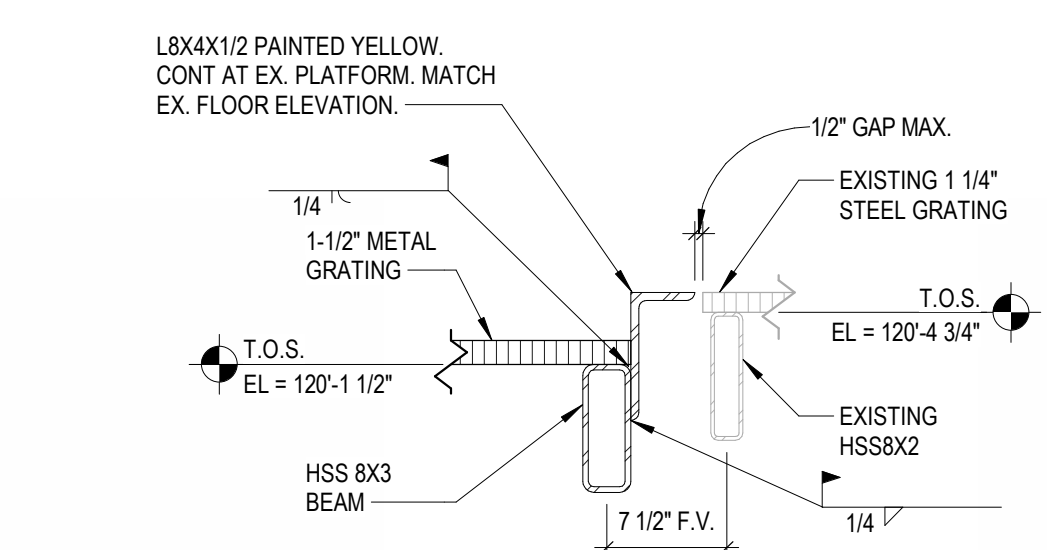

8 UNIT 5 FRAMING DETAIL
1" = 1'-0"

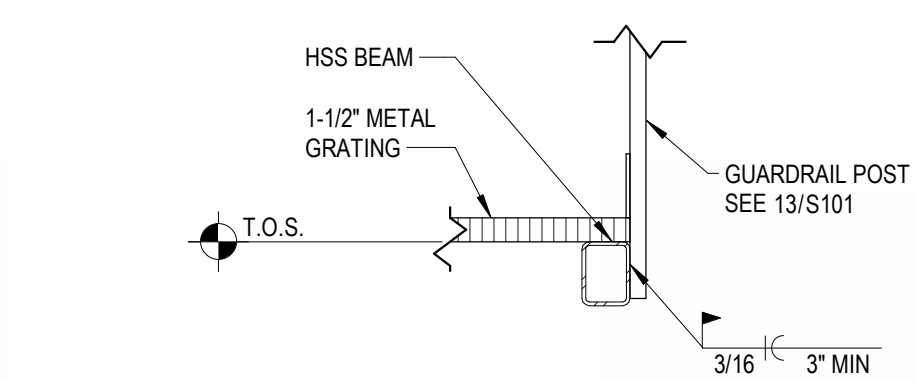

9 GUARDRAIL DETAIL
1" = 1'-0"

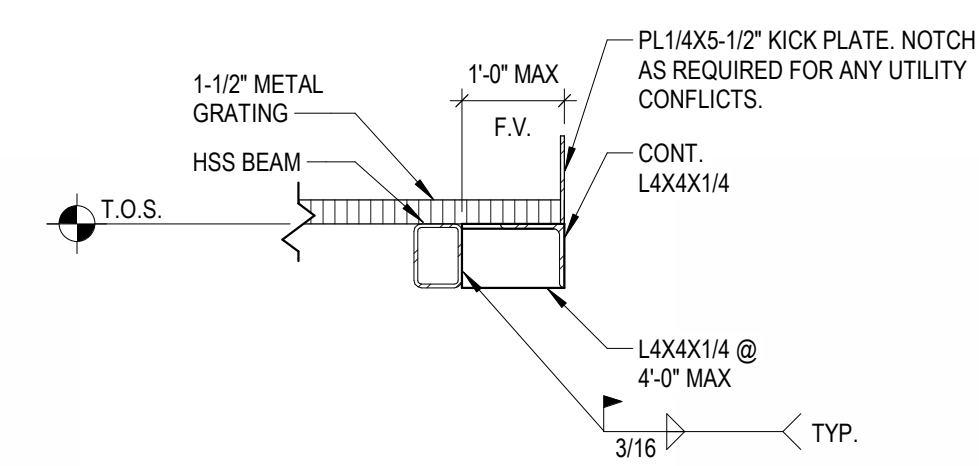

10 ANGLE FRAME KICK PLATE DETAIL
1" = 1'-0"

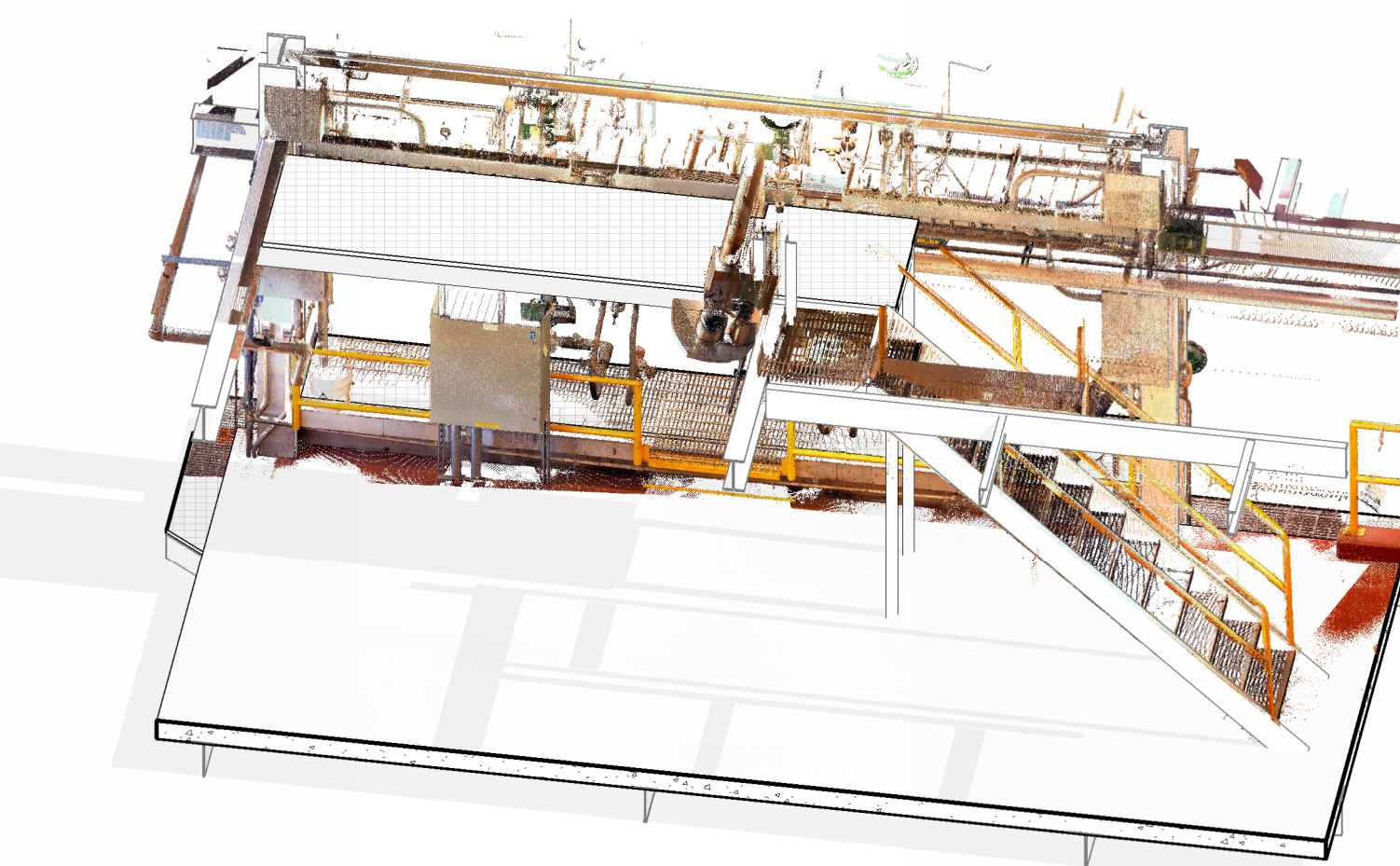

11 3D UNIT 5 PLATFORM

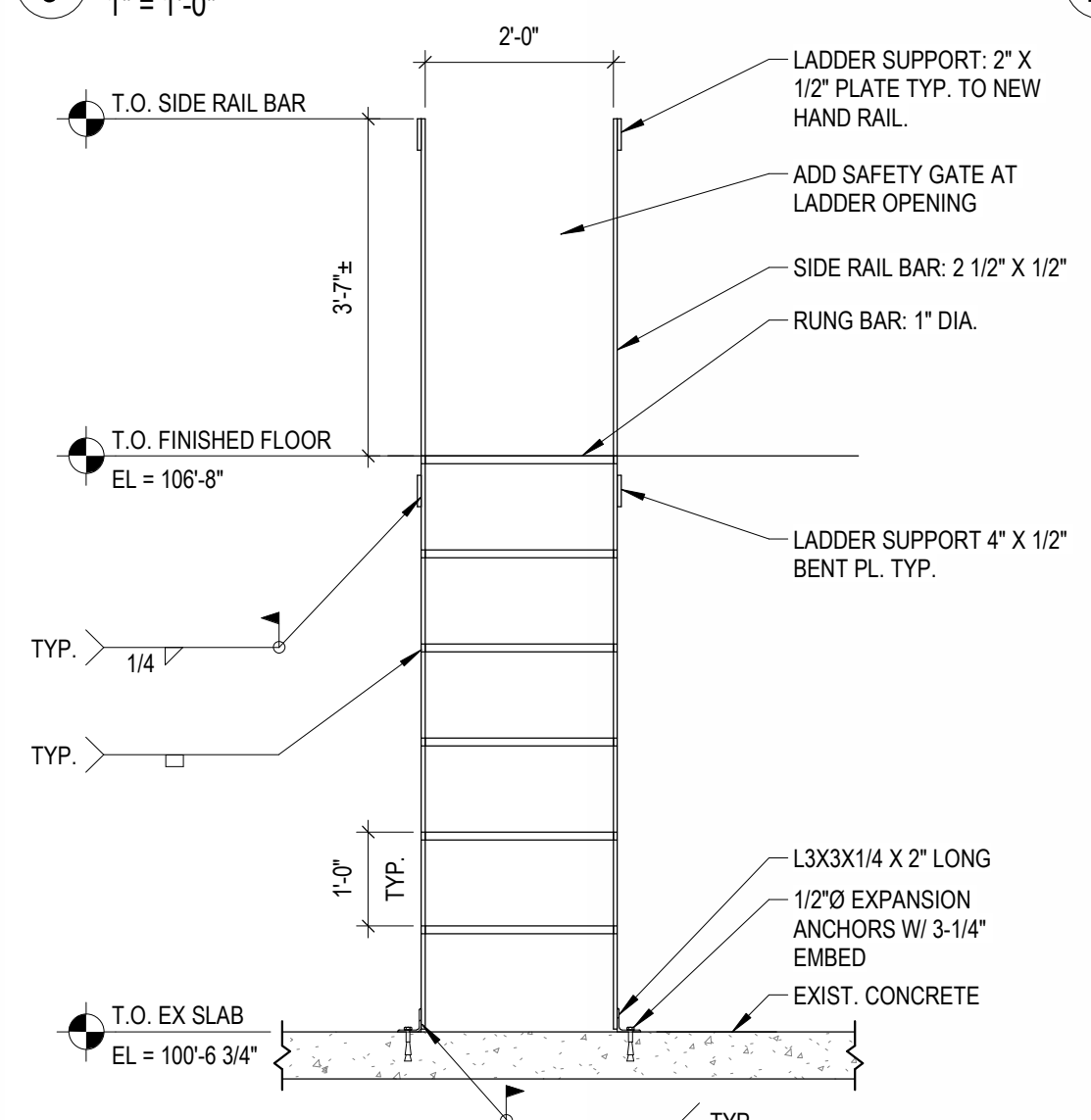

12 TYP LADDER DETAIL
1/2" = 1'-0"

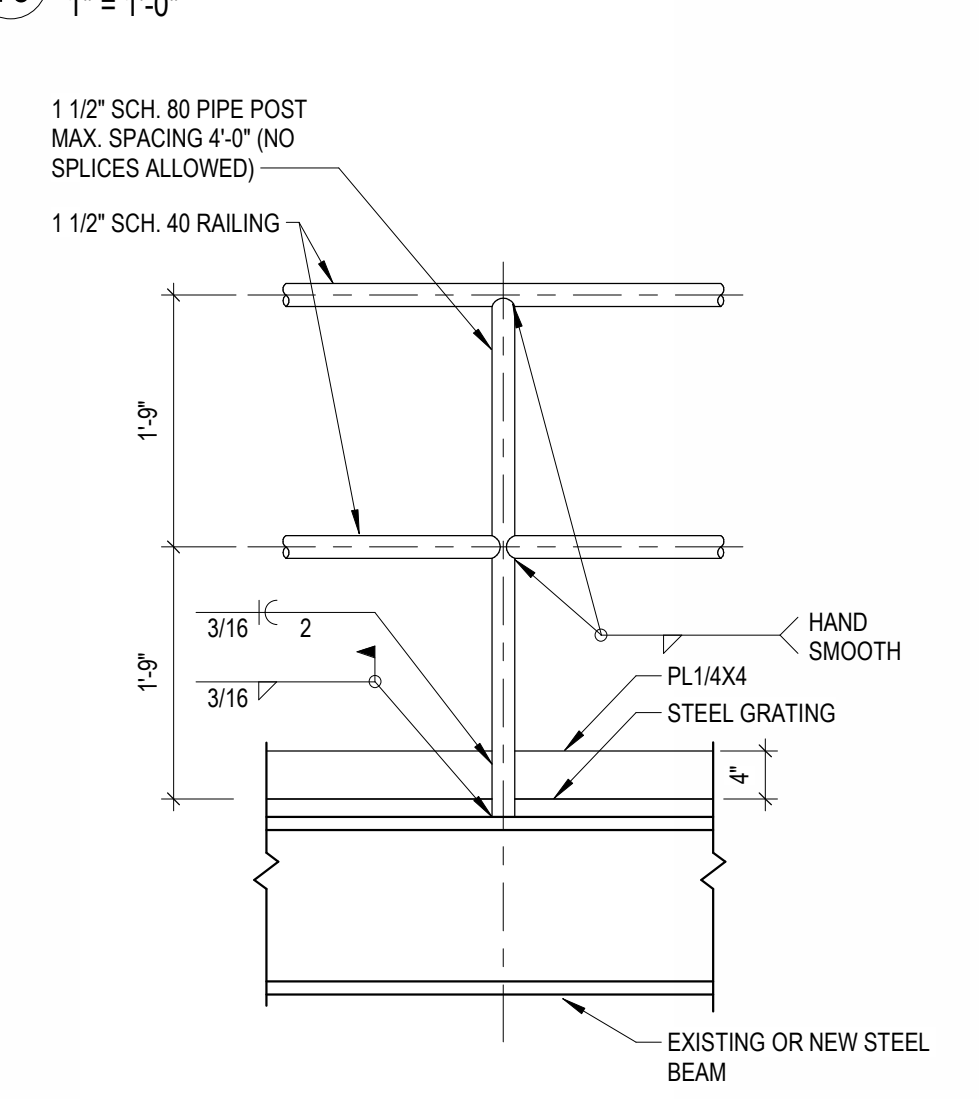

13 TYP HANDRAIL DETAIL
3/4" = 1'-0"

7 UNIT 5 PLATFORM FRAMING PLAN
1/4" = 1'-0"



JEO CONSULTING GROUP

1937 N CHESTNUT ST
WAHOO, NE 68066
800.723.8567 | jeo.com

JEO Consulting, Inc.
Organization Certificate of
Authorization Number: CA-0069



ISSUE

MARK	DATE	DESCRIPTION

HASTINGS NORTH DENVER STATION - UNIT 4 & 5 PLATFORM DESIGN

HASTINGS UTILITIES
1228 NORTH DENVER AVENUE
HASTINGS, NE 68901

JEO Project No: 242382.20
Date: 03.28.2025
QAQC: SWA
Drawn By: DEC
Additional Data 1:
Additional Data 2:



UNIT 4 & 5 FRAMING PLANS, ISOMETRIC VIEWS & DETAILS